

Technical Data Car · 4x4 · Van Tyre

2009 · 2010



THE RAIN  TYRE



This data book contains comprehensive information on Uniroyal Car and Van Tyres. The technical data and other details on tyres and accessories have been compiled to reflect as exactly and completely as possible the current state of development and are based on **ETRTO**¹⁾, **ISO**²⁾ and **WdK/DIN**³⁾ standards.

Most of the Uniroyal tyres comply with **DOT**⁴⁾ regulations and are marked accordingly.

They are homologated in accordance with the relevant **ECE**⁵⁾ regulation (ZR tyres without operational code in accordance with EU guideline 92/23) and are hence also homologated in accordance with current **EU**⁶⁾ tyre regulation.

This databook is intended for information and instruction only. No liability whatsoever will be accepted for damage, regardless of its nature and its legal basis, arising from advice given in this book.

¹⁾ ETRTO – The European Tyre and Rim Technical Organisation, Brussels

²⁾ ISO – International Organization for Standardization

³⁾ DIN – German Institute for Standardisation, Berlin
WdK – German Rubber Manufacturers' Association, Frankfurt/M.

⁴⁾ DOT – Department of Transportation (USA)

⁵⁾ ECE – Economic Commission for Europe (UNO-Institution, Geneva)

⁶⁾ EU – European Union, formerly EEC

Tyre safety tips

We recommend that the **inflation pressure** of every tyre is **checked** at least **every 14 days**. Avoid driving over sharp-edged or pointed objects.

Lower inflation pressures, greater loads or higher speeds than specified by the vehicle and / or tyre manufacturer all shorten the **service life** of tyres and can result in structural damages.

We recommended that **new tyres** are **run in** at moderate speeds for the first 120 to 190 miles (200 to 300 km) to roughen the tread surface. The tyre does not achieve its best performance until after this running-in period.

We recommend all wheel positions of a passenger car are fitted with tyres of the **same tread design**.

Please observe the detailed operating instructions on [page 46 ff.](#)

SAFETY WARNING!



The following instructions must be observed to ensure vehicle safety at all times. This applies especially with

respect to tyre inflation pressure recommendations.

Non-compliance with these instructions means risking tyre damage which, if serious enough, may even result in a tyre bursting. It is hazards like these that can cause traffic accidents involving vehicle damage and/or serious personal injury.

Introduction, Safety Hints	2	
Tyre Sidewall Information	4	
Service description (including Load and Speed Index)	6	
Units of measurement and definitions of the technical data	7	
 Passenger Car tyres:		
Summer tyres	8-12	
Winter tyres	13-14	
4x4 tyres	15	
Technical data car and 4x4 tyres	16-28	
 Van tyres:		
Size ranges	29-31	
Technical data	32-37	
 Tyres for caravans and car draw trailers (special load capacities)		38-40
Tube Table	41	
Car rims	42-45	
 Operating instructions:		
Correct choice of tyre and wheel	46	
Winter tyres	46	
Fitting the tyre	47	
Fitting the wheel to the vehicle	47	
Tyre pressure	48	
Load capacity and speed	51	
Tyre damage	53	
Tyre Rotation on a vehicle	53	
Tyre storage	55	
Tyre repair	57	
Tyre service life for passenger car and light truck	57	
Minimum tread depth	58	
Guidelines on tyre safety	60	
 Index		61-62
Service	63	
Publisher's imprint	59	

- ① **205/55 R 16 91 V** **205** Nominal Section width in mm.
55 Nominal Aspect ratio
(Tyre height is 55 % of tyre width).
R Symbol for radial tyre.
16 Rim diameter Code (in inches).
91 Load Index "91" = max. load of this tyre
is 615 kg (see table page 6)
V Speed Index, indicating max. speed
V=240 km/h / 150 mph (see table page 6)
Other information may be added after the size marking:
"REINFORCED" or **"EXTRA LOAD (XL)"** for reinforced tyres,
"M+S" for winter tyres.
- ② **TUBELESS** tubeless.
(TUBE TYPE tyres must be mounted with tubes).
- ③ **E 4** Marking indicating accordance with ECE regulations. The number
after the E in the circle indicates the country of homologation.
Ⓔ⁴ (4=Netherlands)*
- ④ **1609** Production code ("16" means 16th week,
"09" means 2009).
- ⑤ **TWI** TWI=Tread Wear Indicator.
Cross ribs evenly spaced around the circumference of the tyre
in the longitudinal tread grooves and becoming level with the tread
surface when the remaining tread depth is down to 1.6 mm.
- ⑥ **Made in ...** Marking showing the country of origin.
Other information on the tyre sidewall applies to countries
outside Europe (esp. USA)

⁴) This sign may also be ,
if the tyre was homologated in accordance
with the EU guideline 92/23.

Service description

Including Load Index and Speed Index

Load Index (LI)

The Load Index is a numerical code associated with the maximum load a tyre can carry (see also p. 52).

LI	kg	LI	kg	LI	kg	LI	kg	LI	kg
50	190	65	290	80	450	95	690	110	1060
51	195	66	300	81	462	96	710	111	1090
52	200	67	307	82	475	97	730	112	1120
53	206	68	315	83	487	98	750	113	1150
54	212	69	325	84	500	99	775	114	1180
55	218	70	335	85	515	100	800	115	1215
56	224	71	345	86	530	101	825	116	1250
57	230	72	355	87	545	102	850	117	1285
58	236	73	365	88	560	103	875	118	1320
59	243	74	375	89	580	104	900	119	1360
60	250	75	387	90	600	105	925	120	1400
61	257	76	400	91	615	106	950	121	1450
62	265	77	412	92	630	107	975	122	1500
63	272	78	425	93	650	108	1000	123	1550
64	280	79	437	94	670	109	1030	124	1600

Speed Index (SI)

The Speed Index indicates the maximum speed at which the tyre can carry a load corresponding to its Load Index.

SI	Max. speed for passenger car tyres	
M	81 mph ¹⁾	130 km/h ¹⁾
P	93 mph	150 km/h
Q	100 mph	160 km/h
R	106 mph	170 km/h
S	112 mph	180 km/h
T	118 mph	190 km/h
H	130 mph	210 km/h
V	150 mph	240 km/h
W	169 mph	270 km/h
Y	187 mph	300 km/h
ZR	over 150 mph	over 240 km/h

SI	Reference speed for commercial vehicle tyres	
K	69 mph	110 km/h
L	75 mph	120 km/h
M	81 mph	130 km/h
N	87 mph	140 km/h
P	93 mph	150 km/h
Q	100 mph	160 km/h
R	106 mph	170 km/h
S	112 mph	180 km/h
T	118 mph	190 km/h
H	130 mph	210 km/h

¹⁾ As a rule only used for special spare tyres if they qualify according to ECE Regulation 30. In accordance with ECE Regulation 64 governing the use of special spare tyres, even these more highly rated tyres may only be used up to a maximum speed of 50 mph/80 km/h.

Units of measurement and definitions of the technical data

The technical data in the tables comply generally with international standards.

All **dimensions** in the tables of this databook are given in millimetres (mm), if not indicated in a different way.

The **rim diameter** is given in inch code. Tyre ranges on new rim types may also be marked in mm.

Construction measurements are theoretical values for the design of the tyre: The **width** is relative to the smooth sidewall, the **outer diameter** to the tread centre.

Maximum measurements are actual **operating measurements** of the inflated tyre (operating pressure) in the unloaded state. They include growth but exclude dynamic distortions.

The **width** is the max. permitted tyre width, including sidewall decorative markings, when the tyre is mounted on the correct rim.

The **outer diameter** is the max. permitted diameter. The max. measurements are binding for **vehicle designers**.

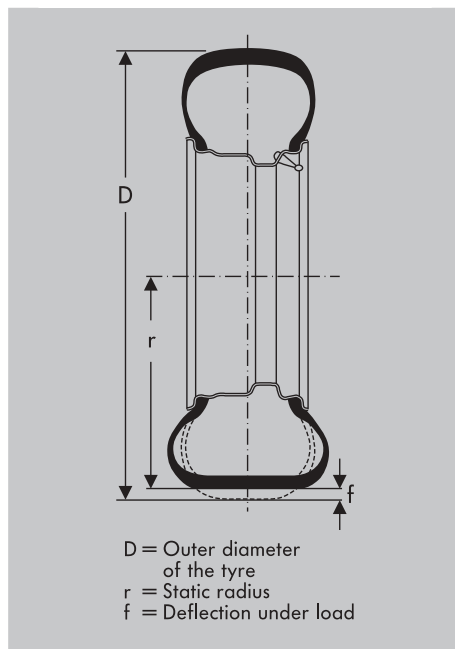
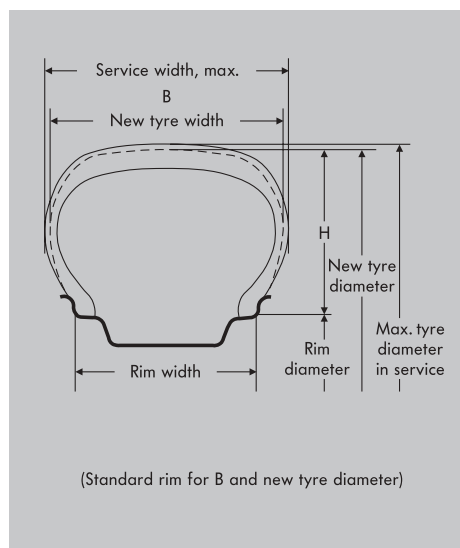

The **static radius** is the distance between the wheel centre and the ground contact patch under max. load at the recommended tyre pressure.

The **rolling circumference** is the distance covered by a point on the circumference when the tyre revolves once at 60 km/h (37 mph).

The **load capacity** in kilograms (kg) is weight in the sense of a mass.

Tyre pressure (inflation pressure) is given in bar as an overpressure (cold tyre), for driving speeds **up to 160 km/h (100 mph)**.

Vehicle designers should bear in mind the **maximum values** for tyre outer diameter and width when planning the **wheel space of a vehicle**, if all standard approved tyres are to fit without any restrictions.

Should this by way of exception not be possible, the safety risk must be eliminated by taking appropriate measures.

The new RainExpert is the perfect choice for compact cars.

- V-shaped tread pattern disperses water more efficiently
→ high degree of protection against aquaplaning
- specially angled sipes in the shoulders and at the center
→ short stopping distances on wet and dry roads
- special indicators help to detect uneven wear at an early stage
→ optimum performance and long service life
- Speed Indices: T/H/V



Size range [see following page](#) →

Size range

80 series		
135/80 R 13	70T	→
145/80 R 13	75T	→
155/80 R 13	79T	
165/80 R 13	83T	→
165/80 R 13 XL	87T	→
175/80 R 14	88T	→
	88H	→
70 series		
145/70 R 13	71T	
155/70 R 13	75T	
165/70 R 13	79T	
175/70 R 13	82T	
	82H	
185/70 R 13	86T	→
165/70 R 14	81T	
	XL 85T	
175/70 R 14	84T	
	XL 88T	
185/70 R 14	88T	→
	88H	→
195/70 R 14	91T	→
	91H	→

65 series		
155/65 R 13	73T	
165/65 R 13	77T	
175/65 R 13	80T	
155/65 R 14	75T	→
165/65 R 14	79T	
175/65 R 14	82T	
	82H	
	XL 86T	
185/65 R 14	86T	
	86H	
195/65 R 14	89T	→
	89H	→
165/65 R 15	81T	→
185/65 R 15	88T	
	88H	
195/65 R 15	91T	
	91H	
	91V	
	XL 95T	
205/65 R 15	94H	→
	94V	→
215/65 R 15	96H	→

60 series		
175/60 R 14	79H	→
185/60 R 14	82T	
	82H	
195/60 R 14	86H	→
185/60 R 15	84	→
	XL 88H	→
195/60 R 15	88H	
	88V	
205/60 R 15	91H	
	91V	
	91W	
	XL 95H	
225/60 R 15	96V	→
	96W	→
205/60 R 16	92H	→
	92V	→
215/60 R 16 XL	99H	→
225/60 R 16	98W	→
235/60 R 16	100W	→

55 series		
185/55 R 14	80H	→
185/55 R 15	82H	→
	82V	→
195/55 R 15	85H	
	85V	
205/55 R 15	88V	→
195/55 R 16	87V	
205/55 R 16	91H	
	91V	
	XL 94V	
215/55 R 16	93V	→
	XL 97H	→
50 series		
195/50 R 15	82H	
	82V	

See cover foldout for footnotes



**The high-performance rain tyre.
The new top-of-the-range rain tyre
that offers maximum performance.
For powerful executive, luxury,
sports and tuned cars.**

- Curved V-shaped tread bar
→ for resistance to aquaplaning
- Red-hot silica compound
→ for shorter braking distances
- Optimized rubber compound
→ for long tyre life
- High Speed Indices: W/Y-ZR



Size range

55 series

205/55 R 16	91 W (ZR)
215/55 R 16	93 W
225/55 R 16	95 V
	95 W (ZR)
XL	99 Y
	FR
215/55 R 17	94 W (ZR)
225/55 R 17	97 W (ZR)
XL	101 W (ZR)

50 series

195/50 R 15	82 V
205/50 R 15	86 V
205/50 R 16	87 V
	87 W (ZR)
225/50 R 16	92 W (ZR)
205/50 R 17 XL	93 W (ZR) FR
215/50 R 17	91 W (ZR) FR
225/50 R 17	94 W (ZR) FR
XL	98 W (ZR) FR

45 series

195/45 R 14	77 V	FR
195/45 R 15	78 V	FR
195/45 R 16 XL	84 V	FR

45 series (continued)

205/45 R 16	83 V	FR
	83 W (ZR)	FR
225/45 R 16	89 W (ZR)	FR
205/45 R 17 XL	88 W (ZR)	FR
215/45 R 17	87 W (ZR)	FR
XL	91 W (ZR)	FR
225/45 R 17	91 W (ZR)	FR
XL	94 Y (ZR)	FR
235/45 R 17	94 W (ZR)	FR
XL	97 W (ZR)	FR
245/45 R 17	95 W (ZR)	FR
225/45 R 18 XL	95 Y (ZR)	FR
245/45 R 18 XL	100 W (ZR)	FR
255/45 R 18 XL	103 Y (ZR)	FR

40 series

215/40 R 16 XL	86 W (ZR)	FR
225/40 R 16	85 W (ZR)	FR
205/40 R 17 XL	84 W (ZR)	FR
215/40 R 17 XL	87 W (ZR)	FR
235/40 R 17	90 W (ZR)	FR
245/40 R 17	91 W (ZR)	FR
255/40 R 17	94 W (ZR)	FR
225/40 R 18 XL	92 W (ZR)	FR

40 series (continued)

235/40 R 18	91 W (ZR)	FR
	XL 95 Y (ZR)	FR
245/40 R 18 XL	97 Y (ZR)	FR
275/40 R 18	99 W (ZR)	FR
245/40 R 19	94 W (ZR)	FR

35 series

215/35 R 18 XL	84 Y (ZR)	FR
255/35 R 18 XL	94 W (ZR)	FR
265/35 R 18	93 W (ZR)	FR
275/35 R 18	95 W (ZR)	FR
215/35 R 19 XL	85 W (ZR)	FR
225/35 R 19 XL	88 Y (ZR)	FR
235/35 R 19 XL	91 W (ZR)	FR
245/35 R 19 XL	93 W (ZR)	FR
255/35 R 19 XL	96 Y (ZR)	FR

30 series

265/30 R 19 XL	93 W (ZR)	FR
275/30 R 19 XL	96 W (ZR)	FR

See cover foldout for footnotes

High performance for medium range to executive cars.

- Advanced double-V tread pattern and special tyre contour concept for optimal water drainage
→ high level of aquaplaning safety
- Advanced Silica compound and intricate tread pattern
→ short braking distances on wet roads
- Optimized tread pattern geometry
→ low noise level and more driving comfort
- Speed Indices: H/V/W



Size range

65 series			60 series			55 series		
195/65 R 14	89H	□	175/60 R 14	79H	□	185/55 R 14	80H	□
205/65 R 15	94H	□	195/60 R 14	86H	□	185/55 R 15	82H	□
	94V	□	185/60 R 15	84H	□		82V	□
215/65 R 15	96H	□		XL 88H	□	205/55 R 15	88V	□
			225/60 R 15	96V	□	215/55 R 16	93V	□
				96W	□	215/55 R 16 XL	97H	□
			205/60 R 16	92H	□			
				92V	□			
			215/60 R 16 XL	99H	□			
			225/60 R 16	98W	□			
			235/60 R 16	100W	□			

See cover foldout for footnotes

**For mini and lower medium range cars.
Quick, manoeuvrable, dynamic.**

- Hydrodynamic V-shaped tread pattern
→ high aquaplaning safety
- Silica compound perfected and angled tread lugs
→ optimum grip in the wet and shorter braking distances
- Highly advanced tread pattern geometry
→ optimized wear and high mileage performance
- Speed Indices: T/ H



Size range

80 series			70 series			65 series		
135/80 R 13	70 T	□	185/70 R 13	86 T	□	155/65 R 14	75 T	□
145/80 R 13	75 T	□	185/70 R 14	88 T	□	195/65 R 14	89 T	□
165/80 R 13	83 T	□		88 H	□	60 series		
	XL	87 T	195/70 R 14	91 T	□	165/60 R 14	75 T	□
175/80 R 14	88 T	□		91 H	□		75 H	□
	88 H	□						

See cover foldout for footnotes

The premium winter tyre for powerful medium range and luxury cars.

- Hydrodynamic, arrowed tread pattern
→ outstanding protection against aquaplaning
- State-of-the-art silica compound and waved sipes
→ great grip for short braking distances
- Optimised tread pattern with more gripping edges
→ more traction and cornering stability in snow and ice
- Speed Indices: T/H/V



Size range

65 series	
175/65 R 15	84 T
185/65 R 15	88 T
195/65 R 15	91 T
	91 H
195/65 R 15 XL	95 T
205/65 R 15	94 T
	94 H
215/65 R 15	96 H
215/65 R 16	98 H
60 series	
185/60 R 15	84 T
185/60 R 15 XL	88 T
195/60 R 15	88 T
	88 H

60 series (continued)	
205/60 R 15	91 H
225/60 R 15	96 H
205/60 R 16	92 H
205/60 R 16 XL	96 H →
215/60 R 16 XL	99 H
225/60 R 16	98 H
235/60 R 16	100 H
55 series	
185/55 R 15	82 T
195/55 R 15	85 H
195/55 R 16	87 T →
205/55 R 16	91 T
	91 H
205/55 R 16 XL	94 H
	94 V
215/55 R 16	93 H
215/55 R 16 XL	97 H
225/55 R 16	95 H
225/55 R 16 XL	99 H
	99 V
225/55 R 17 XL	101 H
	101 V

50 series		
195/50 R 15	82 H	
205/50 R 16	87 H	
225/50 R 16	93 H	
205/50 R 17 XL	93 H	FR
	93 V	FR
225/50 R 17 XL	98 H	FR →
	98 V	FR →
45 series		
225/45 R 17	91 H	FR
225/45 R 17 XL	94 V	FR
235/45 R 17	94 H	FR
235/45 R 17 XL	97 V	FR
40 series		
225/40 R 18 XL	92 V	FR

See cover foldout for footnotes



Top performance in the wet and safe mobility whatever the weather.

- Even better grip in the wet*
- Greater safety in snow and ice*
- Better handling on dry roads*
- High mileage performance

* Compared with its predecessor



Size range

80 series	
135/80 R13	70 Q
145/80 R13	75 Q
155/80 R13	79 Q
175/80 R14	88 T
70 series	
145/70 R13	71 T
155/70 R13	75 T
165/70 R13	79 T
175/70 R13	82 T
165/70 R14	81 T
175/70 R14	84 T
185/70 R14	88 T
195/70 R15 Rf.	97 T ¹⁾

65 series	
155/65 R13	73 T
165/65 R13	77 T
175/65 R13	80 T
155/65 R14	75 T
165/65 R14	79 T
175/65 R14	82 T
175/65 R14 XL	86 T
185/65 R14	86 T
195/65 R14	89 T
155/65 R15	77 T ²⁾

60 series	
165/60 R14	75 T
165/60 R14 XL	79 T
185/60 R14	82 T
55 series	
185/55 R14	80 T

¹⁾ Tread pattern Snow Max
²⁾ Tread pattern MS plus 5

See cover foldout for footnotes

The SUV tyre for vehicles of the middle to upper range.

- Innovative double-V tread pattern combined with an optimized tyre contour for rapid water drainage
→ excellent aquaplaning safety
- Optimized shoulder design and robust tyre construction specially for SUV
→ traction, even in light off the road conditions
- Special Silica compound for SUV tyres
→ good driving stability and short braking distances
- Speed Indices: T/H/V



Size range

80 series	
195/80 R 15	96 H
205/80 R 16 XL	104 T
75 series	
235/75 R 15 XL	109 T

70 series	
205/70 R 15	96 H
255/70 R 15	108 T
265/70 R 15	112 H
215/70 R 16	100 H
225/70 R 16	102 H
235/70 R 16	106 H
245/70 R 16	107 H
265/70 R 16	112 H
275/70 R 16	114 T FR

65 series	
215/65 R 16	98 H
255/65 R 16	109 H
235/65 R 17 XL	108 V FR
265/65 R 17	112 H FR
60 series	
235/60 R 16	100 H
255/60 R 17	106 V
55 series	
225/55 R 17	97 H FR
255/55 R 18 XL	109 H FR

See cover foldout for footnotes



Technical data passenger car tyres and 4x4 tyres

Size	Tyre		Permitted rims ¹⁾ (width code)	Tyre dimension Max. standard value in operation ²⁾		Rolling circumference ³⁾ +1.5% / -2.5% (mm)
	Load Index LI	Max. Load capacity (kg)		Width (mm)	Outer diam. (mm)	
82 series *)						
145 R 10	68	315	3.50 B	148	501	1500
			4.00 B	153		
			4.50 B	158		
			5.00 B	163		
175 R 13	86	530	4.50 B	180	619	1855
			5.00 B	185		
			5.50 B	190		
			6.00 B	195		
165 R 14	84	500	4 J	169	633	1895
			4 ½ J	174		
			5 J	179		
			5 ½ J	184		
185 R 14 Rf.	94	670	4 ½ J	186	662	1985
			5 J	191		
			5 ½ J	196		
			6 J	201		
80 series *)						
135/80 R 13	70	335	3.50 B⁴⁾	138	554	1665
			4.00 B ⁴⁾	143		
			4.50 B ⁴⁾	148		
145/80 R 13	75	387	3.50 B ⁴⁾	146	572	1715
			4.00 B⁴⁾	151		
			4.50 B ⁴⁾	156		
			5 J	161		
155/80 R 13	79	437	4.00 B ⁴⁾	158	588	1765
			4.50 B⁴⁾	163		
			5.00 B ⁴⁾	168		
165/80 R 13	83	487	4.00 B	167	604	1810
165/80 R 13 XL	87	545	4.50 B	172		
			5.00 B	177		
175/80 R 14	88	560	4 ½ J	179	648	1940
			5 J	184		
			5 ½ J	189		
			6 J	194		

See cover foldout for footnotes

Size	Tyre		Permitted rims ¹⁾	Tyre dimension		Rolling circum- ference ³⁾
	Load Index	Max. Load capacity		Max. standard value in operation ²⁾		
	LI	(kg)	(width code)	Width (mm)	Outer diam. (mm)	+1.5% / -2.5% (mm)
80 series *1)						
195/80 R 15	96	710	5 J	199	705	2114
			5 ½ J	204		
			6 J	209		
			6 ½ J	214		
205/80 R 16 XL	104	900	5 J	206	748	2239
			5 ½ J	211		
			6 J	216		
			6 ½ J	221		
			7 J	226		
75 series						
235/75 R 15 XL	109	1030	6 J	239	747	2236
			6 ½ J	244		
			7 J	249		
			7 ½ J	254		
			8 J	259		
70 series						
135/70 R 13	68	315	3.50 B ⁴⁾	139	528	1585
			4.00 B⁴⁾	144		
			4.50 B ⁴⁾	149		
145/70 R 13	71	345	3.50 B ⁴⁾	146	542	1630
			4.00 B ⁴⁾	151		
			4.50 B⁴⁾	156		
			5.00 B ⁴⁾	161		
155/70 R 13	75	387	4.00 B ⁴⁾	158	556	1670
			4.50 B⁴⁾	163		
			5.00 B ⁴⁾	168		
165/70 R 13	79	437	4.00 B ⁴⁾	167	572	1715
			4.50 B ⁴⁾	172		
			5.00 B⁴⁾	177		
			5.50 B ⁴⁾	182		
175/70 R 13	82	475	4.50 B ⁴⁾	179	586	1755
			5.00 B⁴⁾	184		
			5.50 B ⁴⁾	189		
			6.00 B ⁴⁾	194		
185/70 R 13	86	530	4.50 B ⁴⁾	187	600	1800
			5.00 B ⁴⁾	192		
			5.50 B⁴⁾	197		
			6.00 B ⁴⁾	202		

See cover foldout for footnotes



Technical data passenger car tyres and 4x4 tyres

Size	Tyre		Permitted rims ¹⁾ (width code)	Tyre dimension Max. standard value in operation ²⁾		Rolling circumference ³⁾ +1.5 % / -2.5 % (mm)
	Load Index LI	Max. Load capacity (kg)		Width (mm)	Outer diam. (mm)	
70 series						
165/70 R 14	81	462	4 J	167		
165/70 R 14 XL	85	515	4.50 B ⁴⁾	172		
			5.00 B⁴⁾	177	598	1795
			5.50 B ⁴⁾	182		
175/70 R 14	84	500	4 ½ J	179		
175/70 R 14 XL	88	560	5.00 B⁴⁾	184	612	1835
			5.50 B ⁴⁾	189		
			6 J	194		
185/70 R 14	88	560	4 ½ J	187		
			5 J	192		
			5 ½ J	197	626	1880
			6 J	202		
195/70 R 14	91	615	5 J	199		
			5 ½ J	204		
			6 J	209	640	1920
			6 ½ J	214		
195/70 R 15 Rf.	97	730	5 J	199		
			5 ½ J	204		
			6 J	209	665	2000
			6 ½ J	214		
205/70 R 15	96	710	5 J	207		
			5 ½ J	212		
			6 J	217	681	2040
			6 ½ J	222		
			7 J	227		
255/70 R 15	108	1000	6 ½ J	260		
			7 J	265		
			7 ½ J	270	753	2254
			8 J	275		
			8 ½ J	280		
265/70 R 15	112	1120	7 J	272		
			7 ½ J	277		
			8 J	282	767	2297
			8 ½ J	287		
			9 J	292		
215/70 R 16	100	800	5 ½ J	220		
			6 J	225		
			6 ½ J	230	720	2159
			7 J	235		
225/70 R 16	102	850	6 J	232		
			6 ½ J	237	734	2202
			7 J	242		
			7 ½ J	247		

See cover foldout for footnotes

Size	Tyre		Permitted rims ¹⁾	Tyre dimension		Rolling circum- ference ³⁾
	Load Index	Max. Load capacity		Max. standard value in operation ²⁾		
	LI	(kg)	(width code)	Width (mm)	Outer diam. (mm)	+1.5 % / -2.5 % (mm)
70 series						
235/70 R 16	106	950	6 J	240		
			6 ½ J	245		
			7 J	250	750	2245
			7 ½ J	255		
			8 J	260		
245/70 R 16	107	975	6 ½ J	253		
			7 J	258	764	2287
			7 ½ J	263		
			8 J	268		
265/70 R 16	112	1120	7 J	273		
			7 ½ J	278		
			8 J	283	792	2373
			8 ½ J	288		
			9 J	293		
275/70 R 16	114	1180	7 J	280		
			7 ½ J	285		
			8 J	290	808	2416
			8 ½ J	295		
			9 J	300		
65 series						
155/65 R 13	73	365	4.50 B⁴⁾	163	540	1625
			5.00 B ⁴⁾			
			5.50 B ⁴⁾			
165/65 R 13	77	412	4.50 B⁴⁾	172		
			5.00 B⁴⁾	177	552	1660
			5.50 B ⁴⁾	182		
			6.00 B ⁴⁾	187		
175/65 R 13	80	450	5.00 B⁴⁾	184	568	1700
			5.50 B ⁴⁾	189		
			6.00 B ⁴⁾	194		
155/65 R 14	75	387	4.50 B⁴⁾	163	566	1700
			5.00 B ⁴⁾	168		
			5.50 B ⁴⁾	173		
165/65 R 14	79	437	4.50 B ⁴⁾	172		
			5.00 B⁴⁾	177	578	1740
			5.50 B ⁴⁾	182		
			6 J	187		
175/65 R 14	82	475	5.00 B⁴⁾	184	594	1780
175/65 R 14 XL	86	530	5.50 B ⁴⁾	189		
			6 J	194		
			5 ½ J	192		
185/65 R 14	86	530	5 ½ J	192		
			5 ½ J	197	606	1820
			6 J	202		
			6 ½ J	207		

Technical data passenger car tyres and 4x4 tyres

Size	Tyre		Permitted rims ¹⁾	Tyre dimension		Rolling circum- ference ³⁾
	Load Index	Max. Load capacity		Max. standard value in operation ²⁾		
	LI	(kg)	(width code)	Width (mm)	Outer diam. (mm)	+1.5% / -2.5% (mm)
65 series						
195/65 R 14	89	580	5 ½ J	204	620	1860
			6 J	209		
			6 ½ J	214		
			7 J	219		
			4 ½ J	163		
			5 J	168		
155/65 R 15	77	412	5 ½ J	173	591	1780
			5 J	184		
			5 ½ J	189		
175/65 R 15	84	500	6 J	194	619	1855
			5 J	192		
			5 ½ J	202		
185/65 R 15	88	560	6 ½ J	207	631	1895
			5 ½ J	197		
			6 J	202		
195/65 R 15	91	615	6 ½ J	214	645	1935
			6 J	209		
			7 J	219		
195/65 R 15 XL 195/65 R 15 Rf.	95	690	7 ½ J	232	657	1975
			6 J	217		
			6 ½ J	222		
205/65 R 15 205/65 R 15 Rf.	94 99	670 775	7 J	227	657	1975
			6 J	217		
			7 ½ J	232		
215/65 R 15	96	710	6 J	225	673	2015
			6 ½ J	230		
			7 J	235		
			7 ½ J	240		
215/65 R 16	98	750	6 J	225	698	2090
			6 ½ J	230		
			7 J	235		
			7 ½ J	240		
255/65 R 16	109	1030	7 J	265	752	2251
			7 ½ J	270		
			8 J	275		
			8 ½ J	280		
			9 J	285		
235/65 R 17 XL	108	1000	6 ½ J	245	750	2251
			7 J	250		
			7 ½ J	255		
			8 J	260		
			8 ½ J	265		

See cover foldout for footnotes

Size	Tyre		Permitted rims ¹⁾	Tyre dimension		Rolling circum- ference ³⁾
	Load Index	Max. Load capacity		Max. standard value in operation ²⁾		
	LI	(kg)	(width code)	Width (mm)	Outer diam. (mm)	+1.5% / -2.5% (mm)
65 series						
265/65 R 17	112	1120	7 ½ J	278		
			8 J	283	790	2365
			8 ½ J	288		
			9 J	293		
			9 ½ J	298		
60 series						
185/60 R 13	80	450	5.00 B ⁴⁾	192		
			5.50 B⁴⁾	197	560	1685
			6.00 B ⁴⁾	202		
			6 ½ J	207		
165/60 R 14	75	387	4 ½ J	172		
165/60 R 14 XL	79	437	5 J⁵⁾	177	562	1690
			5 ½ J	182		
			6 J	187		
175/60 R 14	79	437	5 J⁵⁾	184	574	1725
			5 ½ J	189		
			6 J	194		
185/60 R 14	82	475	5 J	192		
			5 ½ J	197	586	1765
			6 J	202		
			6 ½ J	207		
195/60 R 14	86	530	5 ½ J	204		
			6 J	209	600	1800
			6 ½ J	214		
			7 J	219		
185/60 R 15	84	500	5 J	192		
185/60 R 15 XL	88	560	5 ½ J	197	611	1840
			6 J	202		
			6 ½ J	207		
195/60 R 15	88	560	5 ½ J	204		
			6 J	209	625	1875
			6 ½ J	214		
			7 J	219		
205/60 R 15	91	615	5 ½ J	212		
205/60 R 15 XL	95	690	6 J	217	637	1910
			6 ½ J	222		
			7 J	227		
			7 ½ J	232		
225/60 R 15	96	710	6 J	232		
			6 ½ J	237	661	1985
			7 J	242		
			7 ½ J	247		
			8 J	252		

See cover foldout for footnotes



Technical data passenger car tyres and 4x4 tyres

Size	Tyre		Permitted rims ¹⁾ (width code)	Tyre dimension Max. standard value in operation ²⁾		Rolling circumference ³⁾ +1.5% / -2.5% (mm)
	Load Index LI	Max. Load capacity (kg)		Width (mm)	Outer diam. (mm)	
60 series						
205/60 R 16	92	630	5 ½ J	212		
205/60 R 16 XL	96	710	6 J	217	662	1990
			6 ½ J	222		
			7 J	227		
			7 ½ J	232		
215/60 R 16 XL	99	775	6 J	225	674	2025
			6 ½ J	230		
			7 J	235		
			7 ½ J	240		
225/60 R 16	98	750	6 J	232	686	2060
			6 ½ J	237		
			7 J	242		
			7 ½ J	247		
			8 J	252		
235/60 R 16	100	800	6 ½ J	245	700	2100
			7 J	250		
			7 ½ J	255		
			8 J	260		
			8 ½ J	265		
255/60 R 17	106	950	7 J	265	750	2251
			7 ½ J	270		
			8 J	275		
			8 ½ J	280		
			9 J	285		
55 series						
195/55 R 13	80	450	5.50 B ⁴⁾	204	552	1660
			6.00 B⁴⁾	209		
			6 ½ J	214		
			7 J	219		
185/55 R 14	80	450	5 J	192	568	1710
			5 ½ J	197		
			6 J	202		
			6 ½ J	207		
185/55 R 15	82	475	5 J	192	593	1785
			5 ½ J	197		
			6 J	202		
			6 ½ J	207		
195/55 R 15	85	515	5 ½ J	204	603	1815
			6 J	209		
			6 ½ J	214		
			7 J	219		

See cover foldout for footnotes

Size	Tyre		Permitted rims ¹⁾ (width code)	Tyre dimension Max. standard value in operation ²⁾		Rolling circum- ference ³⁾ +1.5% / -2.5% (mm)			
	Load Index LI	Max. Load capacity (kg)		Width (mm)	Outer diam. (mm)				
55 series									
205/55 R 15	88	560	5 ½ J	213	617	1850			
			6 J	218					
			6 ½ J	223					
			7 J	228					
			7 ½ J	233					
225/55 R 15	92	630	6 J	232	639	1920			
			6 ½ J	237					
			7 J	242					
			7 ½ J	247					
195/55 R 16	87	545	5 ½ J	204	628	1890			
			6 J	209					
			6 ½ J	214					
205/55 R 16	91	615	5 ½ J	213	642	1930			
			205/55 R 16 XL	94			670	6 J	218
215/55 R 16	93	650	6 J	225	652	1960			
			215/55 R 16 XL	97			730	7 J	235
			7 ½ J	240					
225/55 R 16	95	690	6 J	232	664	1995			
			225/55 R 16 XL	99			775	6 ½ J	237
225/55 R 17	97	730	7 ½ J	247	690	2075			
			8 J	252					
			7 J	242					
			6 J	232					
225/55 R 17 XL	101	825	6 ½ J	237	690	2075			
			7 J	242					
255/55 R 18 XL	109	1030	7 J	266	749	2248			
			7 ½ J	271					
			8 J	276					
			8 ½ J	281					
			9 J	286					

See cover foldout for footnotes



Technical data passenger car tyres and 4x4 tyres

Size	Tyre		Permitted rims ¹⁾ (width code)	Tyre dimension Max. standard value in operation ²⁾		Rolling circumference ³⁾ +1.5% / -2.5% (mm)
	Load Index LI	Max. Load capacity (kg)		Width (mm)	Outer diam. (mm)	
50 series						
195/50 R 15	82	475	5 ½ J	204	585	1760
			6 J	209		
			6 ½ J	214		
			7 J	219		
205/50 R 15	86	530	5 ½ J	213	595	1790
			6 J	218		
			6 ½ J	223		
			7 J	228		
205/50 R 16	87	545	5 ½ J	213	620	1865
			6 J	218		
			6 ½ J	223		
			7 J	228		
205/50 R 16	87	545	7 ½ J	233	620	1865
			5 ½ J	213		
			6 J	218		
			7 J	228		
225/50 R 16	92	630	6 J	232	642	1930
			93	650		
			7 J	242		
			7 ½ J	247		
205/50 R 17 XL	93	650	8 J	252	646	1945
			5 ½ J	213		
			6 J	218		
			6 ½ J	223		
215/50 R 17	91	615	7 J	228	656	1975
			7 ½ J	233		
			6 J	225		
			6 ½ J	230		
225/50 R 17	94	670	7 J	235	656	1975
			7 ½ J	240		
			6 J	232		
			6 ½ J	237		
225/50 R 17 XL	98	750	7 J	242	668	2005
			7 ½ J	247		
			6 J	232		
			8 J	252		

See cover foldout for footnotes

Size	Tyre		Permitted rims ¹⁾ (width code)	Tyre dimension Max. standard value in operation ²⁾		Rolling circum- ference ³⁾ +1.5% / -2.5% (mm)
	Load Index	Max. Load capacity		Width (mm)	Outer diam. (mm)	
	LI	(kg)				
45 series						
195/45 R 14	77	412	6 J	198		
			6 ½ J	203	540	1625
			7 J	208		
195/45 R 15	78	425	7 ½ J	213		
			6 J	198		
			6 ½ J	203	565	1700
195/45 R 16 XL	84	500	7 J	208		
			6 J	198		
			6 ½ J	203	590	1775
205/45 R 16	83	487	7 ½ J	213		
			6 ½ J	209		
			7 J	214	598	1800
225/45 R 16	89	580	7 ½ J	219		
			7 J	229		
			7 ½ J	234	616	1855
205/45 R 17 XL	88	560	8 ½ J	244		
			6 ½ J	209		
			7 J	214	624	1879
215/45 R 17	87	545	7 ½ J	219		
			7 J	222	634	1910
215/45 R 17 XL	91	615	8 J	232		
			7 ½ J	227		
225/45 R 17	91	615	7 J	229		
			7 ½ J	234	641	1930
225/45 R 17 XL	94	670	8 J	239		
			8 ½ J	244		
			7 ½ J	240		
235/45 R 17	94	670	8 J	245	652	1965
			8 ½ J	250		
			9 J	255		
245/45 R 17	95	690	7 ½ J	248		
			8 J	253	660	1990
			8 ½ J	258		
			9 J	263		

See cover foldout for footnotes



Technical data passenger car tyres and 4x4 tyres

Size	Tyre		Permitted rims ¹⁾ (width code)	Tyre dimension Max. standard value in operation ²⁾		Rolling circumference ³⁾ +1.5% / -2.5% (mm)
	Load Index LI	Max. Load capacity (kg)		Width (mm)	Outer diam. (mm)	
45 series						
245/45 R 18 XL	100	800	7 ½ J	248	685	2065
			8 J	253		
			8 ½ J	258		
			9 J	263		
255/45 R 18 XL	103	875	8 J	260	697	2095
			8 ½ J	265		
			9 J	270		
			9 ½ J	275		
40 series						
215/40 R 16 XL	86	530	7 J	222	584	1765
			7 ½ J	227		
			8 J	232		
			8 ½ J	237		
225/40 R 16	85	515	7 ½ J	234	594	1785
			8 J	239		
			8 ½ J	244		
			9 J	249		
205/40 R 17 XL	84	500	7 J	215	602	1820
			7 ½ J	220		
			8 J	225		
215/40 R 17 XL	87	545	7 J	222	610	1840
			7 ½ J	227		
			8 J	232		
			8 ½ J	237		
235/40 R 17	90	600	8 J	246	628	1890
			8 ½ J	251		
			9 J	256		
			9 ½ J	261		
245/40 R 17	91	615	8 J	253	636	1915
			8 ½ J	258		
			9 J	263		
			9 ½ J	268		
255/40 R 17	94	670	8 ½ J	265	644	1940
			9 J	270		
			9 ½ J	275		
			10 J	280		
225/40 R 18 XL	92	630	7 ½ J	234	645	1950
			8 J	239		
			8 ½ J	244		
			9 J	249		

See cover foldout for footnotes

Size	Tyre		Permitted rims (measuring rim bold) ¹⁾ (width code)	Tyre dimension Max. standard value in operation ²⁾		Rolling circum- ference ³⁾ +1.5% / -2.5% (mm)
	Load Index	Load capacity		Width (mm)	Outer diam. (mm)	
	LI	(kg)				
40 series						
235/40 R 18	91	615	8 J	246		
			8 ½ J	251	653	1965
			9 J	256		
			9 ½ J	261		
245/40 R 18	93	650	8 J	253		
			8 ½ J	258	661	1990
			9 J	263		
			9 ½ J	268		
275/40 R 18	99	775	9 J	284		
			9 ½ J	289	685	2065
			10 J	294		
			10 ½ J	299		
245/40 R 19	94	670	8 J	253		
			8 ½ J	258	687	2070
			9 J	263		
			9 ½ J	268		
35 series						
215/35 R 18 XL	84	500	7 J	222		
			7 ½ J	227	613	1850
			8 J	232		
			8 ½ J	237		
255/35 R 18 XL	94	670	8 ½ J	265		
			9 J	270	643	1935
			9 ½ J	275		
			10 J	280		
265/35 R 18	93	650	9 J	277		
			9 ½ J	282	651	1950
			10 J	287		
			10 ½ J	292		
275/35 R 18	95	690	9 J	284		
			9 ½ J	289	657	1980
			10 J	294		
			10 ½ J	299		
215/35 R 19 XL	85	515	7 J	222		
			7 ½ J	227	639	1930
			8 J	232		
			8 ½ J	237		
225/35 R 19 XL	88	560	7 ½ J	234		
			8 J	239	647	1955
			8 ½ J	244		
			9 J	249		

See cover foldout for footnotes



Technical data passenger car tyres and 4x4 tyres

Size	Tyre		Permitted rims (measuring rim bold) ¹⁾ (width code)	Tyre dimension Max. standard value in operation ²⁾		Rolling circum- ference ³⁾ +1.5% / -2.5% (mm)
	Load Index	Load capacity (kg)		Width (mm)	Outer diam. (mm)	
35 series						
235/35 R 19 XL	91	615	8 J	246		
			8 ½ J	251	653	1975
			9 J	256		
			9 ½ J	261		
245/35 R 19 XL	93	650	8 J	253		
			8 ½ J	258	661	2000
			9 J	263		
			9 ½ J	268		
255/35 R 19 XL	96	710	8 ½ J	265		
			9 J	270	669	2015
			9 ½ J	275		
			10 J	280		
30 series						
265/30 R 19 XL	93	650	9 ½ J	282	649	1960
			10 J	287		
			10 ½ J	292		
275/30 R 19 XL	96	710	9 ½ J	289	655	1980
			10 J	294		
			10 ½ J	299		
			11 J	304		

See cover foldout for footnotes

The new economical rain tyre for vans

- Arrow-shaped groove structure and wide channels
→ high aquaplaning protection
- Increased number of sipes and gripping edges
→ short braking distance and improved lateral guidance
- stiff tread ribs and lateral grooves
→ long service life, with optimised cornering stability
- Speed Indices: Q to H



Size range

13 inch					16 inch				
165/70	R 13 C	6 PR	88/86 R	→	175/75	R 16 C	8 PR	101/99 R	→
14 inch					185/75	R 16 C	8 PR	104/102 R	→
185	R 14 C	8 PR	102/100 Q	→	195/75	R 16 C	8 PR	107/105 R	→
195	R 14 C	8 PR	106/104 Q	→	205/75	R 16 C	8 PR	110/108 R	→
165/70	R 14 C	6 PR	89/87 R	→	215/75	R 16 C	8 PR	113/111 R	→
175/65	R 14 C	6 PR	90/88 T	→	195/65	R 16 C	8 PR	104/102 T	→
15 inch								(100 T)	
195/70	R 15 C	8 PR	104/102 R	→	215/65	R 16 C	8 PR	109/107 R	→
205/70	R 15 C	8 PR	106/104 R	→				(106 T)	
215/70	R 15 C	8 PR	109/107 R	→	225/65	R 16 C	8 PR	112/110 R	→
225/70	R 15 C	8 PR	112/110 R	→	235/65	R 16 C	8 PR	115/113 R	→
205/65	R 15 C	6 PR	102/100 T	→	195/60	R 16 C	6 PR	99/97 H	→

See cover foldout for footnotes



The specialist for vans and transporters.

- 3 wide grooves
→ high aquaplaning safety
- Offset lateral gripping edges
→ short braking distance and low noise levels
- Sturdy shoulder ribs and wet weather optimized compound
→ excellent cornering performance, even in the wet
- Speed Indices: Q/R/T



Size range

13 inch				
165/70	R 13 C	6 PR	88/86 R	□
14 inch				
165	R 14 C	6 PR	93/91 P	¹⁾
175	R 14 C	8 PR	99/98 Q	
185	R 14 C	8 PR	102/100 Q	□
195	R 14 C	8 PR	106/104 Q	□
205	R 14 C	8 PR	109/107 P	²⁾
215	R 14 C	8 PR	112/110 P	²⁾
185/75	R 14 C	8 PR	102/100 Q	
165/70	R 14 C	6 PR	89/87 R	□
175/65	R 14 C	6 PR	90/88 T	□
15 inch				
185	R 15 C	8 PR	103/102 R	³⁾
195/70	R 15 C	8 PR	104/102 R	□
215/70	R 15 C	8 PR	109/107 R	□ ³⁾
225/70	R 15 C	8 PR	112/110 R	□
205/65	R 15 C	6 PR	102/100 T	□

16 inch				
175/75	R 16 C	8 PR	101/99 R	□
185/75	R 16 C	8 PR	104/102 R	□
195/75	R 16 C	8 PR	107/105 R	□
205/75	R 16 C	8 PR	110/108 R	□
215/75	R 16 C	8 PR	113/111 R	□
225/75	R 16 C	10 PR	121/120 R	
195/65	R 16 C	8 PR	104/102 T	□
			(100 T)	
205/65	R 16 C	8 PR	107/105 T	
			(103 T)	
215/65	R 16 C	8 PR	109/107 R	□
			(106 T)	
225/65	R 16 C	8 PR	112/110 R	□
195/60	R 16 C	6 PR	99/97 H	□
Reinforced				
195/70	R 15 Rf.		97 T	
205/65	R 15 Rf.		99 T	

See cover foldout for footnotes

¹⁾ Tread pattern MAX 380 ²⁾ Tread pattern MAX C50 ³⁾ Tread pattern MAX 400

The winter tyre for vans and transporters as versatile as winter weather.

- Wide drainage channels
→ high aquaplaning safety
- Stepped sipes mean
→ safe braking in snow and ice
- Wedge-shaped tread grooves and angled tread lugs
→ provide efficient grip when setting off and accelerating
- Speed Indices: Q/R/T



Size range

13 inch				16 inch			
165/70	R 13 C	6 PR	88/86 R	175/75	R 16 C	8 PR	101/99 R
14 inch				185/75	R 16 C	8 PR	104/102 R
185	R 14 C	8 PR	102/100 Q	195/75	R 16 C	8 PR	107/105 R
195	R 14 C	8 PR	106/104 Q	205/75	R 16 C	8 PR	110/108 R
205	R 14 C	8 PR	109/107 P ¹⁾	215/75	R 16 C	8 PR	113/111 R
215	R 14 C	8 PR	112/110 P ¹⁾	195/65	R 16 C	8 PR	104/102 T
165/70	R 14 C	6 PR	89/87 R				(100 T)
175/65	R 14 C	6 PR	90/88 T	205/65	R 16 C	8 PR	107/105 T
15 inch							(103 T)
195/70	R 15 C	8 PR	104/102 R	215/65	R 16 C	8 PR	109/107 R
205/70	R 15 C	8 PR	106/104 R				(106 T)
215/70	R 15 C	8 PR	109/107 R	225/65	R 16 C	8 PR	112/110 R
225/70	R 15 C	8 PR	112/110 R	195/60	R 16 C	6 PR	99/97 T
205/65	R 15 C	6 PR	102/100 T	Reinforced			
				195/70	R 15 Rf.		97 T

See cover foldout for footnotes

¹⁾ Tread pattern MAX CMS PLUS

Technical data van tyres

Size	Tyre		Rim 6)	Tube and valve (TL valve)	Tyre dimension				new	
	PR	Service description 5)			Max. standard value in operation 7)				Width	Outer diam.
					Stand- ard	Spe- cial	Stand- ard	Spe- cial		
13 inch										
165/70 R 13 C	6	88/86 R	4 ½ J 5 J	43 GS 11.5 (1330, 38 G 11.5)	172 177		572	576	165 170	562
14 inch										
165 R 14 C	6	93/91 P	4 J 4 ½ J 5 J	–	167 172 177	– – –	630	–	162 167 172	622
175 R 14 C	8	99/98 Q	4 ½ J 5 J 5 ½ J	(43 GS 11.5)	178 183 188	187 192 197	642	648	172 178 183	634
185 R 14 C	8	102/100 Q	5 J 5 ½ J 6 J	(43 GS 11.5)	189 194 199	198 203 208	659	665	183 188 193	650
195 R 14 C	8	106/104 Q	5 J 5 ½ J 6 J	(43 GS 11.5)	199 204 209	209 214 219	675	682	193 198 203	666
205 R 14 C	8	109/107 P	5 ½ J 6 J 6 ½ J	(43 GS 11.5)	209 214 219	220 225 230	696	703	203 208 213	686
215 R 14 C	8	112/110 P	5 ½ J 6 J 6 ½ J	(43 GS 11.5)	220 225 230	230 235 240	710	717	213 218 223	700
185/75 R 14 C	8	102/100 Q	5 J 5 ½ J 6 J	(43 GS 11.5)	191 196 201	– – –	646		184 189 194	634
165/70 R 14 C	6	89/87 R	4 ½ J 5 J	– (1430, 38 G 11.5)	172 177		598	602	165 170	588
175/65 R 14 C	6	90/88 T	5 J 5 ½ J	–	186 191		594	598	177 182	584

See cover foldout for footnotes

Radius stat. +/-2% (mm)	Rolling circum- ference +1.5%/ -2.5% (mm)	PR	Load Index LI	Wheel posi- tion 8)	Load capacity (kg) per axle at a tyre pressure (bar)								Speed Index and reference speed (km/h)
					3.0	3.25	3.5	3.75	4.0	4.25	4.5	4.75	
258	1703	6	88 86	S T	935 1775	1000 1890	1060 2005	1120 2120					R 170
284	1885	6	93 91	S T	1085 2060	1160 2195	1230 2330	1300 2460					P 150
289	1920	8	99 98	S T	1120 2170	1195 2310	1270 2450	1340 2590	1410 2730	1480 2865	1550 3000		Q 160
296	1970	8	102 100	S T	1230 2315	1310 2465	1390 2620	1470 2765	1545 2915	1625 3060	1700 3200		Q 160
302	2020	8	106 104	S T	1375 2605	1465 2775	1555 2945	1645 3110	1730 3275	1815 3440	1900 3600		Q 160
310	2080	8	109 107	S T	1490 2820	1590 3005	1685 3190	1780 3370	1875 3550	1970 3725	2060 3900		P 150
316	2121	8	112 110	S T	1620 3065	1725 3270	1830 3470	1935 3665	2040 3860	2140 4050	2240 4240		P 150
289	1920	8	102 100	S T	1175 2215	1255 2360	1330 2505	1405 2650	1480 2790	1555 2930	1630 3065	1700 3200	Q 160
268	1795	6	89 87	S T	970 1825	1035 1945	1100 2065	1160 2180					R 170
287	1780	6	90 88	S T	1005 1875	1070 2000	1135 2120	1200 2240					T 190

Technical data van tyres

Size	Tyre		Rim 6)	Tube and valve (TL valve)	Tyre dimension				new	
	PR	Service description 5)			Max. standard value in operation 7)				Width	Outer diam.
					Width Stand- ard	Spe- cial	Outer diam. Stand- ard	Spe- cial		
15 inch										
185 R 15 C	8	103/102 R	5 J	(43 GS 11.5)	189	-	683		183	674
			5 ½ J		194	-			188	
			6 J		199	-			193	
195/70 R 15 C	8	104/102 R	5 J	-	199		665	672	191	655
			5 ½ J		204				196	
			6 J		209				201	
205/70 R 15 C	8	106/104 R	5 ½ J	(43 GS 11.5)	212		681	687	204	669
			6 J		217				209	
			6 ½ J		222				214	
215/70 R 15 C	8	109/107 R	5 ½ J	(43 GS 11.5)	220		695	701	211	683
			6 J		225				216	
			6 ½ J		230				221	
225/70 R 15 C	8	112/110 R	6 J	(43 GS 11.5)	232		709	715	223	697
			6 ½ J		237				228	
			7 J		242				233	
205/65 R 15 C	6	102/100 T	5 ½ J	(43 GS 11.5)	212		657	663	204	647
			6 J		217				209	
			6 ½ J		222				214	
16 inch										
175/75 R 16 C	8	101/99 R	4 ½ J	(43 GS 11.5)	179		678	684	172	668
			5 J		184				177	
			5 ½ J		189				182	
185/75 R 16 C	8	104/102 R	5 J	(43 GS 11.5)	191		696	700	184	684
			5 ½ J		196				189	
			6 J		201				194	
195/75 R 16 C	8	107/105 R	5 J	(43 GS 11.5)	199		710	716	191	698
			5 ½ J		204				196	
			6 J		209				201	
205/75 R 16 C	8	110/108 R	5 ½ J	(43 GS 11.5)	211		726	732	203	714
			6 J		216				208	
			6 ½ J		221				213	

See cover foldout for footnotes

Radius	Rolling circumference	PR	Load Index LI	Wheel position 8)	Load capacity (kg) per axle at a tyre pressure (bar)								Speed Index and reference speed (km/h)	
					3.0	3.25	3.5	3.75	4.0	4.25	4.5	4.75		
stat. +/-2% (mm)	+1.5%/ -2.5% (mm)													
308	2042	8	103 102	S T	1265 2460	1350 2620	1435 2780	1515 2940	1595 3095	1675 3250	1750 3400		R 170	
300	1985	8	104 102	S T	1300 2460	1385 2620	1470 2780	1555 2940	1640 3095	1720 3250	1800 3400		R 170	
306	2027	8	106 104	S T	1375 2605	1465 2775	1555 2945	1640 3110	1730 3275	1815 3440	1900 3600		R 170	
311	2069	8	109 107	S T	1490 2820	1590 3005	1685 3190	1780 3370	1875 3550	1970 3725	2060 3900		R 170	
317	2112	8	112 110	S T	1620 3065	1725 3270	1830 3470	1935 3665	2040 3860	2140 4050	2240 4240		R 170	
297	1960	6	102 100	S T	1420 2675	1515 2855	1605 3030	1700 3200					T 190	
308	2024	8	101 99	S T	1140 2145	1215 2290	1290 2430	1360 2565	1435 2700	1505 2835	1575 2970	1650 3100	R 170	
314	2073	8	104 102	S T	1245 2355	1330 2510	1410 2665	1490 2815	1570 2965	1645 3110	1725 3255	1800 3400	R 170	
320	2115	8	107 105	S T	1350 2560	1440 2730	1525 2900	1615 3060	1700 3225	1785 3385	1865 3545	1950 3700	R 170	
328	2170	8	110 108	S T	1470 2770	1565 2955	1660 3135	1755 3310	1850 3485	1940 3660	2030 3830	2120 4000	R 170	

Technical data van tyres

Size	Tyre		Rim 6)	Tube and valve (TL valve)	Tyre dimension				new	
	PR	Service description 5)			Max. standard value in operation 7)				Width	Outer diam.
					Width Stand- ard	Spe- cial	Outer Stand- ard	Spe- cial		
16 inch										
215/75 R 16 C	8	113/111 R	5 ½ J	(43 GS 11.5)	220	740	748	211	728	
			6 J		225			216		
			6 ½ J		230			221		
			7 J		235			226		
225/75 R 16 C	10	121/120 R	6 J	(40 MS)	232	758	764	223	744	
			6 ½ J		237			228		
			7 J		242			233		
195/65 R 16 C	8	104/102 T (100 T)	5 J	–	199			191		
			5 ½ J		204			196		
			6 J		209	670	676	201	660	
205/65 R 16 C	8	107/105 T (103 T)	5 ½ J	(43 GS 11.5)	212		686	204	672	
			6 J		217			209		
			6 ½ J		222			214		
215/65 R 16 C	8	109/107 R (106 T)	6 J	(43 GS 11.5)	225	698	702	216	686	
			6 ½ J		230			221		
			7 J		235			226		
225/65 R 16 C	8	112/110 R	6 J	(43 GS 11.5)	232	710	716	223	698	
			6 ½ J		237			228		
			7 J		242			233		
235/65 R 16 C	8	115/113 R	6 ½ J	TR 600 XHP, TR 602 HP, 40 MS	245	724	730	235	712	
			7 J		250			240		
			7 ½ J		255			245		
195/60 R 16 C	6	99/97 H 99/97 T	5 ½ J	–	204	650	654	196	640	
			6 J		209			201		
			6 ½ J		214			206		

See cover foldout for footnotes

Radius stat. +/-2% (mm)	Rolling circum- ference +1.5%/ -2.5% (mm)	PR	Load Index LI	Wheel posi- tion 8)	Load capacity (kg) per axle at a tyre pressure (bar)								Speed Index and reference speed (km/h)
					3.0	3.25	3.5	3.75	4.0	4.25	4.5	4.75	
334	2210	8	113 111	S T	1590 3020	1700 3220	1800 3415	1905 3610	2005 3800	2105 3990	2205 4175	2300 4360	R 170
338	2254	10	121 120	S T	1725 3330	1835 3550	1950 3765	2060 3980	2170 4190	2275 4395	2385 4605	2490 4805	→
305	2000	8	104 102	S T	1245 2355	1330 2510	1410 2665	1490 2815	1570 2965	1645 3110	1725 3255	1800 3400	R 170
308	2036	8	107 105	S T	1350 2560	1440 2730	1525 2900	1615 3060	1700 3225	1785 3385	1865 3545	1950 3700	T 190
313	2077	8	109 107	S T	1425 2700	1520 2880	1615 3055	1705 3230	1795 3400	1885 3570	1975 3735	2060 3900	R 170 T 190
318	2115	8	112 110	S T	1550 2935	1655 3130	1755 3320	1855 3510	1950 3695	2050 3880	2145 4060	2240 4240	R 170
325	2155	8	115 113	S T	1680 3185	1795 3395	1905 3605	2010 3805	2120 4010	2225 4210	2330 4405	2430 4600	R 170
297	1939	6	99 97	S T	1295 2445	1380 2605	1465 2765	1550 2920					T 190 H 210
					5.0	5.25	5.5	5.75					
Continued					2595	2695	2800	2900	R 170				
225/75 R 16 C					5010	5205	5405	5600					

Tyres for caravans and car drawn trailers

Increased load capacity of tyres on caravans and lightweight trailers (only applies to trailers with a max. speed of 100 km/h or 62 mph entered in the car registration documents).

Size	LI	Max. Load capacity (kg)	Inflation pressure (bar)
PASSENGER / 4x4 TYRES			
82 series			
145 R 10	68	345	2.4
175 R 13	86	585	2.5
165 R 14	84	550	2.5
185 R 14 Rf.	94	735	3.2
80 series			
135/80 R 13	70	370	2.6
145/80 R 13	75	425	2.6
155/80 R 13	79	480	2.6
165/80 R 13 /	83	535	2.6
XL	87	600	3.0
175/80 R 14	88	615	2.6
195/80 R 15	96	780	2.6
205/80 R 16 XL	104	990	3.1
75 series			
235/75 R 15 XL	109	1135	3.1
70 series			
135/70 R 13	68	345	2.7
145/70 R 13	71	380	2.7
155/70 R 13	75	425	2.7
165/70 R 13	79	480	2.7
175/70 R 13	82	525	2.7
185/70 R 13	86	585	2.7
165/70 R 14 /	81	510	2.7
XL	85	565	3.1
175/70 R 14	84	550	2.7
XL	88	615	3.1
185/70 R 14	88	615	2.7
195/70 R 14	91	675	2.7
195/70 R 15 Rf.	97	805	3.1
205/70 R 15	96	780	2.7
255/70 R 15	108	1100	2.7
265/70 R 15	112	1230	2.7
215/70 R 16	100	880	2.7
225/70 R 16	102	935	2.7
235/70 R 16	106	1045	2.7
245/70 R 16	107	1070	2.7
265/70 R 16	112	1230	2.7
275/70 R 16	114	1300	2.7

Size	LI	Max. Load capacity (kg)	Inflation pressure (bar)
PASSENGER / 4x4 TYRES			
65 series			
155/65 R 13	73	400	2.7
165/65 R 13	77	455	2.7
175/65 R 13	80	495	2.7
155/65 R 14	75	425	2.7
165/65 R 14	79	480	2.7
175/65 R 14 /	82	525	2.7
XL	86	585	3.1
185/65 R 14	86	585	2.7
195/65 R 14	89	640	2.7
155/65 R 15	77	455	2.7
175/65 R 15	84	550	2.7
185/65 R 15	88	615	2.7
195/65 R 15 /	91	675	2.7
XL / Rf.	95	760	3.1
205/65 R 15 /	94	735	2.7
Rf.	99	855	3.1
215/65 R 15	96	780	2.7
255/65 R 16	109	1135	2.7
235/65 R 17 XL	108	1100	3.1
265/65 R 17	112	1230	2.7
60 series			
185/60 R 13	80	495	2.7
165/60 R 14 /	75	425	2.7
XL	79	480	3.1
175/60 R 14	79	480	2.7
185/60 R 14	82	525	2.7
195/60 R 14	86	585	2.7
185/60 R 15 /	84	550	2.7
XL	88	615	3.1
195/60 R 15	88	615	2.7
205/60 R 15	91	675	2.7
XL	95	760	3.1
225/60 R 15	96	780	2.7
205/60 R 16	92	695	2.7
XL	96	780	3.1
215/60 R 16 XL	99	855	3.1
225/60 R 16	98	825	2.7
235/60 R 16	100	880	2.7
255/60 R 17	106	1045	2.7

Tyres for caravans and car drawn trailers

Increased load capacity of tyres on caravans and lightweight trailers (only applies to trailers with a max. speed of 100 km/h or 62 mph entered in the car registration documents).

Size	LI	Max. Load capacity (kg)	Inflation pressure (bar)
PASSENGER / 4x4 TYRES			
55 series			
195/55 R 13	80	495	2.7
185/55 R 14	80	495	2.7
185/55 R 15	82	525	2.7
195/55 R 15	85	565	2.7
205/55 R 15	88	615	2.7
225/55 R 15	92	695	2.7
195/55 R 16	87	600	2.7
205/55 R 16 / XL	91 94	675 735	2.7 3.1
215/55 R 16 / XL	93 97	715 805	2.7 3.1
225/55 R 16 / XL	95 99	760 855	2.7 3.1
225/55 R 17 XL	97 101	805 910	2.7 3.1
255/55 R 18 XL	109	1135	3.1
50 series			
195/50 R 15	82	525	2.7
205/50 R 15	86	585	2.7
205/50 R 16	87	600	2.7
225/50 R 16	92 93	695 715	2.7 2.7
205/50 R 17 XL	93	715	3.1
215/50 R 17	91	675	2.7
225/50 R 17	94	735	2.7
225/50 R 17 XL	98	825	3.1
45 series			
195/45 R 14	77	455	2.7
195/45 R 15	78	470	2.7
195/45 R 16 XL	84	550	3.1
205/45 R 16	83	535	2.7
225/45 R 16	89	640	2.7
205/45 R 17 XL	88	615	3.1
215/45 R 17 / XL	87 91	600 675	2.7 3.1
225/45 R 17 / XL	91 94	675 735	2.7 3.1

Size	LI	Max. Load capacity (kg)	Inflation pressure (bar)
PASSENGER / 4x4 TYRES			
45 series (continued)			
235/45 R 17 / XL	94 97	735 805	2.7 3.1
245/45 R 17	95	760	2.7
245/45 R 18 XL	100	800	3.1
255/45 R 18 XL	103	965	3.1
40 series			
215/40 R 16 XL	86	585	3.1
225/40 R 16	85	565	2.7
205/40 R 17 XL	84	550	3.1
215/40 R 17 XL	87	600	3.1
235/40 R 17	90	660	2.7
245/40 R 17	91	675	2.7
255/40 R 17	94	735	2.7
225/40 R 18 XL	92	695	3.1
235/40 R 18	91	675	2.7
245/40 R 18	93	715	2.7
275/40 R 18	99	855	2.7
245/40 R 19	94	735	2.7
35 series			
215/35 R 18 XL	84	550	3.1
255/35 R 18 XL	94	735	3.1
265/35 R 18	93	715	2.7
275/35 R 18	95	760	2.7
215/35 R 19 XL	85	565	3.1
225/35 R 19 XL	88	615	3.1
235/35 R 19 XL	91	675	3.1
245/35 R 19 XL	93	715	3.1
255/35 R 19 XL	96	780	3.1
30 series			
265/30 R 19 XL	93	715	3.1
275/30 R 19 XL	96	780	3.1



Tyres for caravans and car drawn trailers

Increased load capacity of tyres on caravans and lightweight trailers (only applies to trailers with a max. speed of 100 km/h or 62 mph entered in the car registration documents).

Size	LI	Max. Load capacity (kg)**	Inflation pressure (bar)
COMMERCIAL-C-TYRES*			
165/70 R 13 C	88	590	3.75
165 R 14 C	93	685	3.75
175 R 14 C	99	815	4.5
185 R 14 C	102	895	4.5
195 R 14 C	106	1000	4.5
205 R 14 C	109	1080	4.5
215 R 14 C	112	1175	4.5
185/75 R 14 C	102	895	4.75
165/70 R 14 C	89	610	3.75
175/65 R 14 C	90	630	3.75

*) 14, 15 and small 16 inch C tyres with treads like pass. car tyres for service on delivery vans. For other C tyres, see Technical Databook for Truck Tyres.

) also for C tyres: Load capacity **per tyre (single fitment)

Size	LI	Max. Load capacity (kg)**	Inflation pressure (bar)
COMMERCIAL-C-TYRES*			
185 R 15 C	103	920	4.5
195/70 R 15 C	104	945	4.5
205/70 R 15 C	106	1000	4.5
215/70 R 15 C	109	1080	4.5
225/70 R 15 C	112	1175	4.5
205/65 R 15 C	102	895	3.75
COMMERCIAL-C-TYRES*			
175/75 R 16 C	101	865	4.75
185/75 R 16 C	104	945	4.75
195/75 R 16 C	107	1025	4.75
205/75 R 16 C	110	1115	4.75
215/75 R 16 C	113	1210	4.75
225/75 R 16 C	121	1525	5.75
195/65 R 16 C	104	945	4.75
205/65 R 16 C	107	1025	4.75
215/65 R 16 C	109	1080	4.75
225/65 R 16 C	112	1175	4.75
235/65 R 16 C	115	1275	4.75
195/60 R 16 C	99	815	3.75

Conditions of use:

An increase of 10% resp. 5% for C tyres over the load capacity as quoted in these tables is permitted when tyres are fitted to caravans and light trailers with a maximum operating speed up to 100 km/h (62 mph). The basic inflation pressure for passenger tyres should be increased by 0.2 bar, as quoted in these tables.

Tube table

Inner tube group	Tyre sizes (radial tyres)	
1020	145; 165/70	R 10 R 10
1210	125; 145/70	R 12 R 12
1220	135-150 155/70	R 12 R 12
1230	155; 165 165/70; 175/70	R 12 R 12
1320	135-150 145/70; 155/70	R 13 R 13
1330	155-165 165/70; 175/70	R 13 R 13
1340	175-185 185/70; 195/70	R 13 R 13

Inner tube group	Tyre sizes (radial tyres)	
1420	135-150 155/70	R 14 R 14
1430	155-165 165/70; 175/70	R 14 R 14
1440	170-185 185/70; 195/70	R 14 R 14
1460	195-205 205/70; 215/70	R 14 R 14
1510	125	R 15
1520	135-150 155/70	R 15 R 15
1530	155-165 165/70; 175/70	R 15 R 15
1540	170-185 185/70; 195/70	R 15 R 15
1550	6.70-7.60	R 15
1560	195; 205 205/70; 215/70; 225/70	R 15 R 15

**Valve for all tubes indicated: 38 G 11.5.
In tyres of 65-series and below tubes
must not be mounted.**

Car rims

The rim is the part of the wheel which supports the tyre.

1. Important elements of the rim

Rim flange = lateral support for the tyre bead

Flange distance = clear rim width

Bead seat = base on which the tyre bead is seated

Well = inner side of the rim

Diameter = specified diameter
flange / bead seat

Hump = continuous raised section of the rim bead seat which enables a better fitting of tubeless tyre beads at **low pressure.**^{*)}

2. Types of rims

The well-base rim is virtually the only type of rim used on cars, caravans and other car trailers:

Well-base rims = one-piece rims, deepened well for easier tyre fitting, 5° tapered bead seat, "x" in the wheel size designation.

Virtually only J and B versions of the well-base rim are used and these are explained here in more detail.

If rubber valves (snap-in type) are used on rims for higher speeds, these must be fitted with **valve supports** where necessary. Also refer to the section "Fitting the tyre".

3. Wheel disc (nave)

The wheel disc is the linking element between the rim and the axle hub. Of all the measurements for wheel linking elements – centre bore and bore diameter, bolt hole type and **offset depth** – the latter is a particularly important factor for the free movement of the tyre in any wheel position.

(Offset depth = 0, when the rim centre and hub contact area of the wheel disc are in line).

4. Wheel strength

The wheel manufacturer must confirm that the wheel strength is adequate for each particular application.

5. Lateral and true running of the wheels (without tyres)

On cars which are virtually all able to considerably exceed 100 km/h (62 mph), it is particularly important that the wheels of the vehicle are **well-centred**.

There should be as little radial and lateral run-out as possible on both bead seat / flange sides of the rim, in order to achieve **good smooth running**.

The standard shows max. tolerances of 1.20 mm. This dimension is for the centre of the tyre seat area or the centre of the flange height. All measurements, particularly the **uniformity**, should be well within these tolerances.

^{*)} Safety shoulders (e.g. hump) are prescribed for tubeless radial car tyres. They should also be used for tubeless truck C tyres with a 14, 15 or 16 code for the rim diameter.

R_4 and R_5 : between 4 and 10 mm

R_5 : not larger than 10 mm

Valve Hole- \varnothing :

11.5 mm ($11.3_{-0}^{+0.4}$) centrally in the side of the rim well.

16.0 mm ($15.7_{-0}^{+0.4}$) only with \varnothing -Code 15.

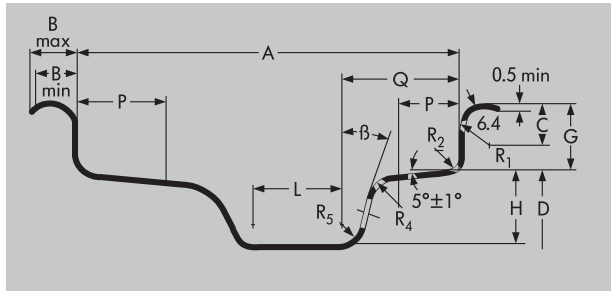

Rim Contour	Dimensions (mm)										
	A	B		G	P	H	L	Q	R ₁	R ₂	β
		Min	Max 1)	± 0.6	Min	Min 2)	Min	Max	Min	Max	Min
3.00 B	76	10	13	14.1	13	15	16	28	7.5	4.5	10°
3.50 B	89				15		34				
4.00 B	101.5				19.5		22	45			
4.50 B	114.5										
5.00 B	127										
5.50 B	139.5										
6.00 B	152.5	11	15	17.3	13	17.3	16	28	9.5	6.5	20°
3 J	76				13		34				
3 1/2 J	89										
4 J	101.5				19.5		22	45			
4 1/2 J	114.5										
5 J	127										
5 1/2 J	139.5										
6 J	152.5				19.5		22	45			
6 1/2 J	165										
7 J	178										
7 1/2 J	190.5										
8 J	203										
8 1/2 J	216										
9 J	228.5	228.5	241.5	254							
9 1/2 J	241.5										
10 J	254										
10 1/2 J	266.5										
11 J	279.5	279.5	292	292							
11 1/2 J	292										

1) B max. values may be exceeded on rims for light commercial vehicles

2) Minimum dimensions for well depth (H) and well angle are required for tyre mounting

Rim diameter

Code (ins)	10	12	13	14	15	16	17	18	19
D (mm)	253.2	304.0	329.4	354.8	380.2	405.6	436.6	462.0	487.4



Car rims

Special rim executions for passenger cars

In many countries safety rims must be used for tubeless radial tyres.

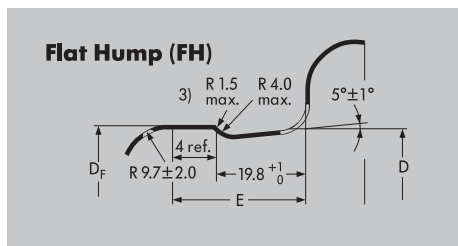
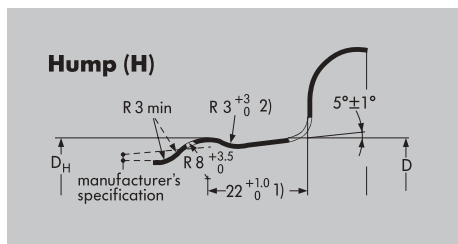

1) In most car rims 19.8 mm.

2) For B-Rims R = 8.5 mm max. resp. R = 4 ± 1 mm.

3) Deburred

These **full-drop centre rims with safety shoulders** for cars, estate cars and light trucks are marked with the following codes shown after rim size designation:

H = one-sided round hump on outer shoulder (formerly: H 1)

H 2 = double round hump

FH = flat hump on outer shoulder (formerly: FHA 1)

FH 2 = double flat hump (formerly: FHA 2)

CH = combination hump = flat hump on outer shoulder, round hump on inner shoulder (formerly: FHA-H)

SL = special ledge

EH 2 = Extended Hump (with extended hump on both sides) (see following page)

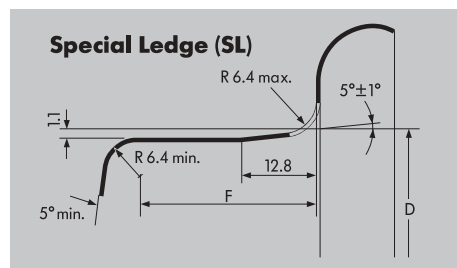

Ledge	Rim diameter Code (ins)	Dimensions (mm)		
		H	FH	
		Circumference $\pi \cdot D_H$ (+ 0 / - 3)	Circumference $\pi \cdot D_F$ (+ 0 / - 3)	E Max.
B	12	957.6	-	-
	13	1037.0	1034.8	24.5
	14	1116.8	1114.6	
J	13	1037.0	1034.8	28.5
	14	1116.8	1114.6	
	15	1196.6	1194.6	
	16	1276.4	1274.2	
	17	1373.8	1371.6	
	18	1453.6	1451.4	
	19	1533.4	1531.2	

Extended Hump – with extended hump on both sides (EH 2)

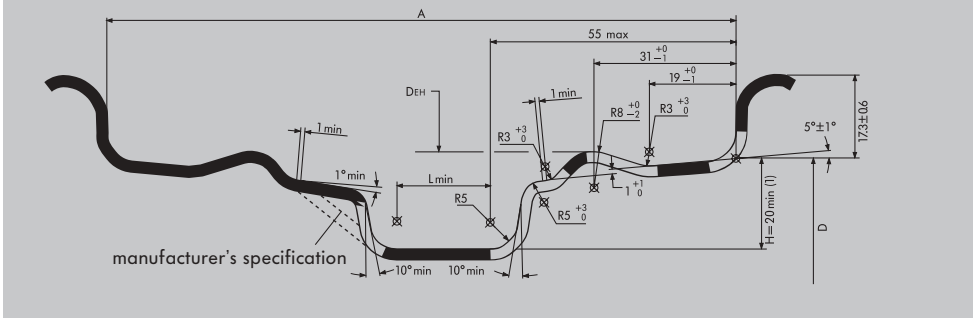

This contour is valid for rim sizes from 5 1/2 J up to 13 1/2 J

(1): H ≥ 22 necessary for automatic fitting two beads at once

Extended Hump – with extended hump on both sides (EH 2+)

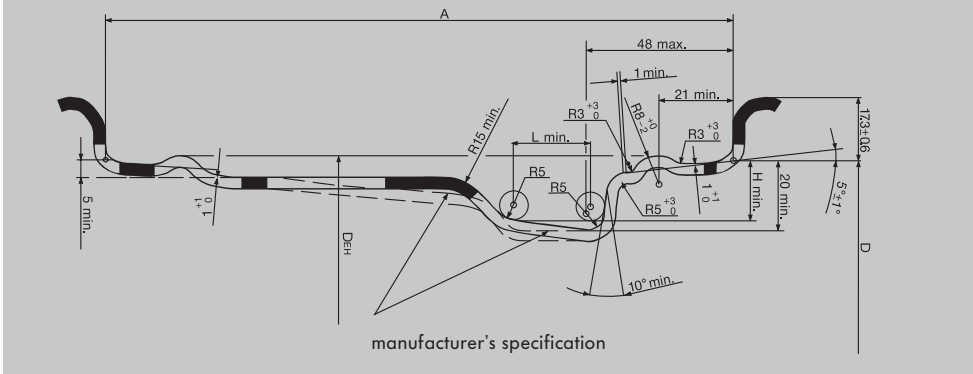

Extended Hump circumference

Rim diameter (code)	Extended Hump circumference (mm) $\pi \cdot D_{EH} + 0/-3.0$
15	1204.2
16	1284
17	1381.2
18	1461
19	1540.8
20	1620.6
21	1700.4



Operating instructions

SAFETY WARNING!



The following instructions must be observed to ensure vehicle safety at all times. Disregarding the fitting instructions could endanger the safety of the tyre fitter or driver.

This applies in particular to inflation pressure.

Non-compliance with these instructions means risking tyre damage which, if serious enough, may result in a tyre bursting. It is an hazard like this that can cause traffic accidents involving vehicle damage and/or serious personal injury.

Correct choice of tyre and wheel

Tyres can be properly maintained only if they are chosen in accordance with vehicle documents and recommendations of the tyre manufacturer.

The use of **higher grade tyres** of the same size is permitted: Higher speed categories, i.e. "H" instead of "T". Greater load capacity, i.e. Load Index 82 instead of 80. Both factors may be combined, i.e. greater load and speed.

If tyres are changed to a different size, all legal requirements and regulations, as well as the recommendations of the vehicle, wheel and tyre manufacturers must be complied with. In any event, the freedom of motion of the wheel and adequate load capacity of the tyre must be observed.

Tyre sizes and rims not entered in the vehicle registration document may only be fitted if the vehicle and tyre manufacturer issue a **certificate of non-objection** or if a public authority issues fitting approval after an inspection by an officially authorised expert**).

80 and 82 series passenger car tyres of the same size can be interchanged without new approval and without any new entry in the vehicle documents if LI and SI of the

interchanging size are of an equivalent or higher-grade quality. Example: 155/80 R13 79T replaces 155 R13 79T.

Mixed tyre constructions for cars, caravans and other car trailers are not permitted: Tyres fitted on any one vehicle must all be either radial or cross-ply. (Exception: Use of the spare tyre in an emergency).

The same applies to the choice of **wheels (rims)**: The standard wheels approved by the vehicle manufacturer must be used as recommended.

The **tyre widths** given in the tables on pages 16–28 and 32–37 refer to the **measuring rim** (bold print in the tables). In the event of a change in the rim width by +1/2 inch, the tyre width changes by approx. +5 mm.

Winter tyres

Winter tyres are clearly superior in the cold months of the year; they offer a wider margin of safety and better economy when the temperature drops below 7°C. Winter tyres approved for a max. speed lower than that of the vehicle may only be fitted if the max. speed of these tyres is displayed in full view of the driver, e.g. on a clearly visible sticker on the dashboard**). This maximum tyre speed must not be exceeded.

A combination of summer and winter tyres on passenger cars is not recommended. In most European countries either summer or winter (M + S) tyres are specified for any one axle; in some countries¹⁾ this applies to all four wheel positions.

Winter tyres have to meet special requirements, meaning that the legal minimum tread depth of 1.6 mm is inadequate. **The suitability limit for winter use is a tread depth of 4 mm.** Uniroyal recommends replacing winter tyres before the tread depth drops below 4 mm for winter service. Such tyres can still be used in summer.

¹⁾ Exception: In Austria, passenger car winter tyres with less than 4 mm remaining tread depth are no longer legally considered to be winter tyres.

^{**)} Exception: This does not apply to the UK.

Top safety in winter can be provided only by true winter tyres on all axle positions (4 tyres).



Snowflake designation (in USA and Canada): This additional marking on an M + S tyre shows that the tyre meets prescribed test criteria and ensures good winter properties.

Fitting the tyre

SAFETY WARNING!



If a tyre is not properly fitted it may burst. The energy released in a blow-out can cause fatal injuries so tyres must be fitted by an expert. Only approved fitting tools and lubricants may

be used. Please observe all fitting instructions.

Before the old tyre is taken off the valve insert must be unscrewed and removed to ensure all air has escaped.

The new tyre and rim must have matching diameters and be approved as a combination suitable for the vehicle model concerned. Only rims of the correct size in perfect condition and free of rust should be used. They must not be damaged, out of shape or worn.

When fitting new tube-type tyres, always use **new tubes**. As tubes stretch in service, there is a risk of folds forming in old tubes, so re-used tubes could suddenly tear.

For safety reasons, tubeless tyres should always be fitted with **new valves**.

If rubber valves (snap-in types) are used for tubeless tyres, the vehicle manufacturer's instructions must be complied with in all cases. A **valve support** (i.e. a stopper on the rim itself or the hubcap) should be fitted, if H, V, W, Y or ZR tyres are specified for the vehicle. This ensures that valves are not forced off at high speeds.

Always coat the tyre beads and the rim with a **fitting lubricant** recommended by the tyre manufacturer. This applies in particular to low section tyres. Never use greases or other hydrocarbons for this purpose.

While the tyre is being inflated, the wheel must remain firmly secured on the mounting machine. **Never inflate an unsecured tyre.** If a loose tyre bursts, the wheel could be thrown around, causing damage.

Keep a reasonable distance from any tyre that is being inflated. Make use of a sufficiently long and secured extension hose with an integrated pressure gauge. **Never bend over a tyre while it is being inflated!**

When fitting tubeless car tyres, care should be taken to ensure that the tyre beads coming from the well-base first clear the hump in the rim shoulder. To avoid cracks in the bead core, the **"pop" pressure** necessary should not exceed 3.3 bar. If the tyre does not pop into place even at this pressure, the pressure must be lowered, and the cause identified and eliminated. Then the procedure can be repeated.

Only when the tyre beads are seated correctly on the rim shoulder may the pressure be increased to achieve the required press-fit and firm grip on the rim flanges. However, this **"fitting pressure"** should not exceed 150% of the max. pressure given in the tables or be more than 4.0 bar. After this, adjust the pressure to the **operating pressure** specified by the vehicle manufacturer (see Uniroyal tyre pressure table).

Car tyres should be **dynamically balanced** to achieve smooth running.

Fitting the wheel to the vehicle

Vehicle axle data such as toe-in, camber angle and wheel castor as well as axle alignment must be checked and, if necessary, be adjusted to within tolerances. Only then should new tyres be fitted.

Operating instructions

When fitting a tyre, make sure that the wheel is centred on the axle hub. If necessary, re-balance the wheel electronically once it is fitted on the vehicle.

Valves should be fitted with **valve caps** – preferably with a sealing ring – as they protect the delicate **valve inserts** and the inside of the tyre.

When mounting **wheel caps and wheel trim rings**, sufficient clearance to the tyre sidewall must be maintained. The wheel cap or wheel trim ring may not come in contact with the tyre under any operating conditions (e.g. brutal braking maneuvers, fast cornering). The diameter of the wheel cap and the wheel trim ring may not extend beyond the rim flange edge. This applies in particular to tyres with rim protection (flange rib "FR").

Directional tyres must be fitted so that they roll in the direction of the arrow on the sidewall as the vehicle moves forward.

Exception: For a short-term use as a temporary fitment spare; but revert to specified fitted position at the earliest possible opportunity!

Modern **asymmetrical tyres** are frequently non-directional. These tyres must be fitted with the sidewall 'Outside' on the outside of the vehicle so that their asymmetrical treads can be used to best effect.

Tyres with both of these properties, i.e. that are directional and asymmetrical, must in addition be fitted on the correct side of the vehicle, i.e. on the left or on the right to comply with both of the instructions above.

Tyre pressure

SAFETY WARNING!



Incorrect tyre pressure can lead to the inside of the tyre being damaged. This can result in tyre problems or even a blow-out. Hidden tyre problems are not rectified by adjusting the tyre pressure.

Table 1:

Load capacities and tyre pressures – standard car tyres

(The tyre pressure values shown here apply to speeds up to 160 km/h (100 mph) for camber angles not greater than 2°)

Load Index	Load capacity (kg) at tyre pressure (bar)					
	2.0	2.1	2.2	2.3	2.4	2.5
62	220	230	240	250	255	265
63	230	235	245	255	265	272
64	235	245	255	260	270	280
65	245	250	260	270	280	290
66	250	260	270	280	290	300
67	255	265	275	285	295	307
68	265	275	285	295	305	315
69	270	285	295	305	315	325

Continued see page 49

Table 1 (continued):

Load capacities and tyre pressures – standard car tyres

Load Index	Load capacity (kg) at tyre pressure (bar)					
	2.0	2.1	2.2	2.3	2.4	2.5
70	280	290	300	315	325	335
71	290	300	310	325	335	345
72	295	310	320	330	345	355
73	305	315	330	340	355	365
74	315	325	340	350	365	375
75	325	335	350	360	375	387
76	335	350	360	375	385	400
77	345	360	370	385	400	412
78	355	370	385	400	410	425
79	365	380	395	410	425	437
80	375	390	405	420	435	450
81	385	400	415	430	445	462
82	395	415	430	445	460	475
83	405	425	440	455	470	487
84	420	435	450	470	485	500
85	430	450	465	480	500	515
86	445	460	480	495	515	530
87	455	475	490	510	525	545
88	470	485	505	525	540	560
89	485	505	525	545	560	580
90	500	520	540	560	580	600
91	515	535	555	575	595	615
92	525	550	570	590	610	630
93	545	565	585	610	630	650
94	560	585	605	625	650	670
95	575	600	625	645	670	690
96	595	620	640	665	685	710
97	610	635	660	685	705	730
98	625	650	675	700	725	750
99	650	675	700	725	750	775
100	670	695	720	750	775	800
102	710	740	765	795	825	850
106	795	825	860	890	920	950
107	815	850	880	910	945	975
108	835	870	905	935	970	1000
109	860	895	930	965	995	1030
112	935	975	1010	1050	1085	1120
114	985	1025	1065	1105	1140	1180

Operating instructions

Table 2:

Load capacities and tyre pressures – Reinforced and Extra Load car tyres

Load Index	Load capacity (kg) at tyre pressure (bar)									
	2.0	2.1	2.2	2.3	2.4	2.5	2.6	2.7	2.8	2.9
84	370	385	400	415	430	445	460	470	485	500
85	385	400	415	430	445	455	470	485	500	515
86	395	410	425	440	455	470	485	500	515	530
87	405	420	435	455	470	485	500	515	530	545
88	415	435	450	465	480	495	515	530	545	560
91	455	475	495	510	530	545	565	580	600	615
92	470	485	505	525	540	560	575	595	615	630
93	485	500	520	540	560	575	595	615	630	650
94	500	520	535	555	575	595	615	635	650	670
95	515	535	555	575	595	615	630	650	670	690
96	525	550	570	590	610	630	650	670	690	710
97	540	565	585	605	625	650	670	690	710	730
98	555	580	600	625	645	665	685	710	730	750
99	575	600	620	645	665	690	710	730	755	775
100	595	620	640	665	690	710	735	755	780	800
101	615	635	660	685	710	735	755	780	800	825
103	650	675	700	725	750	775	800	825	850	875
108	745	770	800	830	860	890	915	945	970	1000
109	765	795	825	855	885	915	945	975	1000	1030

The tyre must be inflated to the pressure specified by the vehicle and tyre manufacturer. This varies depending on the load and service conditions.

The pressure always refers to the **cold** tyre and must not be allowed to fall below this value. The pressure inside warm tyres – driving causes heat build-up – is naturally higher. So never reduce the pressure of warm tyres. Once they cool down, their pressure could fall below the specified **minimum tyre pressure**.

Tyre pressure must be checked and adjusted regularly every 14 days on the cold tyre. The spare tyre may not be forgotten.

Incorrect tyre pressure causes premature and/or uneven tread wear. **Under-inflated** tyres have a higher **rolling resistance**, and this means a higher **fuel consumption**.

The tyre pressure values for car tyres given in table 1 and 2 are **minimum pressures** for speeds up to 160 km/h (100 mph). They may be increased, for example, for reasons of driving stability.

3.2 bar is the **maximum tyre pressure** on standard version car tyres up to and including Speed Index T; 3.5 bar for H-, V-, W-, Y- and ZR-, as well as M + S and XL/Reinforced tyres.

These values may not be exceeded to ensure that the structural performance of the tyres and rims is not impaired.

ZR tyres without service description have from 160 km/h (100 mph) to 190 km/h (118 mph) inclusive the stated pressure of 2.5 bar. Then the inflation pressure must be increased by 0.1 bar for each 10 km/h (6 mph) up to 3.0 bar at 240 km/h (150 mph) under full load and maximum 2° wheel camber.

Table 3:

For **higher speeds** the **tyre pressure** should be **increased** in regard of the load capacity (see table 4, taken from the ETRTO Standards Manual):

Speed capacity of the vehicle (incl. tolerance, about 9 km/h, 6 mph) (km/h)	Speed Indices									
	Q	R	S	T	U	H	V	W	Y	
	Tyre pressure* (bar)									
≤ 160	2.5	2.5	2.5	2.5	2.5	2.5	2.5	2.5	2.5	2.5
170		2.6	2.6	2.6	2.6	2.6	2.6	2.6	2.5	2.5
180			2.6	2.6	2.6	2.6	2.6	2.6	2.5	2.5
190				2.7	2.7	2.7	2.7	2.7	2.5	2.5
200					2.7	2.7	2.7	2.7	2.6	2.5
210						2.8	2.8	2.8	2.7	2.5
220							2.8	2.8	2.8	2.5
230							2.8	2.9	2.9	2.6
240							2.8	3.0	3.0	2.7
250								3.0	3.0	2.8
260									3.0	2.9
270									3.0	3.0
280										3.0
290										3.0
300										3.0

Load capacity and speed

When determining the minimum tyre size necessary for a vehicle, the permitted **axle load** and the **maximum design speed** of the vehicle must be used as a basis.

The maximum load capacity of a car tyre is expressed through its **Load Index (LI)** (see p. 6).

* at the maximum load of the tyre, up to 2° wheel camber

Operating instructions

Table 4:

Percentage of load capacity versus speed¹⁾

(taken from the ETRTO Standards Manual)

Speed capacity of the vehicle (incl. tolerance, about 1% V _{max} + 6.5 km/h) (km/h)	Speed Indices			
	H	V	W	Y
	%			
210	100	100	100	100
220	–	97	100	100
230	–	94	100	100
240	–	91	100	100
250	–	–	95	100
260	–	–	90	100
270	–	–	85	100
280	–	–	–	95
290	–	–	–	90
300 ²⁾	–	–	–	85

¹⁾ For intermediate maximum speeds, linear interpolation of the tyre load capacity is permitted.

²⁾ For speeds over 300 km/h (187 mph), the relevant inflation pressures will be agreed between vehicle and tyre manufacturers (or their national associations), taking into consideration the vehicle characteristics and the type of service.

For **ZR tyres** without service description the maximum load capacity given in the tables from [page 16](#) onwards applies to speeds up to 240 km/h (150 mph).

For speeds over 240 km/h (150 mph) please refer to us for load capacity and tyre pressure.

If car tyres are to be used on a vehicle with a **wheel camber** of over 2°, please check load capacity and tyre pressure with us.

In the absence of such information, the following ETRTO recommendation can be used for tyres at speeds over 160 km/h (100 mph): For a **wheel camber** exceeding **2° and up to and including 4°**, the load capacity is to be reduced linearly **from 100% to 90%**.

Instead of a reduction in tyre load capacity, **inflation pressure** may be **increased** as a function of load.

The tyre pressure calculated for the speed concerned must be multiplied by the following correction factor (f), depending on the actual camber angle > 2°:

$$f = \frac{1}{\sqrt[1.25]{1.0 - 0.01 \times (\text{allowance for the load capacity as a \%})}}$$

The value of f for the following camber angles is shown below:

Camber angle	2°	2.5°	3°	3.5°	4°
f	1.0	1.03	1.07	1.10	1.14

In general, the camber angle of vehicles should not exceed 4°.

On vehicles with speeds in excess of 270 km/h (169 mph), the camber angle should not exceed 3° including any tolerance.

The load capacity of tyres in **twin fitment** is 1.85 times the load capacity of a single tyre.

The **load capacities** in the tables for car tyres can be increased if the tyres are fitted on vehicles with **the following low type-related** max. speeds if the inflation pressure is increased at the same time (taken from the ETRTO Standards Manual).

Max. speed capability	(km/h)	60	50	40	30	25
Load capacity	(%)	110	115	125	135	142
Inflation pressure increase	(bar)	0.1	0.2	0.3	0.4	0.5

Tyre damage

Most tyre damage is caused by incorrect tyre pressure, so we recommend a regular tyre pressure check every 2 weeks. When the car has been driven and the tyres are warm, it is normal for the **tyre pressure to increase**. Do not reduce extra pressure caused by a heat build-up.

A balanced, even **style of driving** is beneficial for the tyres and the environment. Harsh acceleration, braking with locked wheels and fast steering movements shorten the **service life** of tyres.

This applies equally to other types of **tyre strain** such as severe scuffing along the kerb, or driving over rough surfaces. This can cause hidden or visible **damage** to tyres.

Sudden **vibrations** of the steering wheel could point to tyre damage. All the vehicle's tyres should be checked immediately for damage.

Overstressing of tyres (excessive speed or overloading), is to be avoided. This has the same critical effect as **under-inflation** and can cause heat damage to the tyre.

Tyre Rotation on a vehicle

The tyres on a vehicle should be rotated regularly to help ensure even wear and maximum tread life.

Tyres should be rotated as instructed in the vehicle owner's manual, with special attention being given to the **recommended interval for rotating tyres**. Unless otherwise specified by the vehicle manufacturer, tyres should be rotated every 10,000 to 12,000 kilometers – or even earlier if the tread shows signs of uneven wear. In the latter case, the vehicle's wheel alignment and pertinent mechanical components should be checked and corrected, if need be.

Full-size **spare tyres** (not temporary spares) of the same size and design as the tyres in use on the vehicle should be included in the tyre rotation. In conjunction with the rotation, the full-size spare tyre's inflation pressure should be checked and, if need be, corrected.

A tyre's **inflation pressure** must correspond to what is specified in the vehicle owner's manual for the respective tyre position (recommended inflation pressure may differ for the front- and rear-axle tyres).

Operating instructions

Tyre rotation may effect the **tyre pressure monitoring system (TPMS)**. The vehicle owner's manual or a qualified service professional should be consulted in the event that the TPMS has to be adjusted or recalibrated.

The **rolling direction** of directional tyres should not be reversed when the tyres are rotated.

Mixing tyres should be avoided

Tyre size, Load Index (LI) and Speed Index (SI) at all wheel positions should be in accordance with the vehicle manufacturer's specification. In many countries, this is a legal requirement.

Driving with a non-recommended mix of tyre sizes, designs and Speed Indices can be dangerous. In the event that tyres of different sizes, designs, Load or Speed Index are to be fitted on a vehicle, the vehicle manufacturer's recommendations should be heeded and/or the advice of a qualified tyre specialist sought. Some vehicles leave the factory with different tyre sizes on the front and rear axles. This configuration must not be changed unless approved by the vehicle manufacturer.

No more than one temporary spare should be used on a vehicle at any one time. A tyre of this kind should only be used at a certain speed and for a certain distance, as indicated on the tyre sidewall and/or on a label attached to the tyre or the wheel.

Mounting new tyres on the rear axle

It is recommended that all tyres used on the vehicle be replaced at the same time. If this is not the case, at least all the tyres on the same axle should be replaced at the same time.

If only one axle set of tyres is replaced, it is recommended to fit the newest tyres on the rear axle. This may complicate tyre rotation and caution is advised if the tyres differ in terms of state of wear, size, design and Speed Index, for example. In this case it is strongly recommended that a trained tyre specialist be consulted.

The point of the above mounting recommendation is to increase traction on the rear axle. This is important in avoiding oversteer and loss of vehicle stability on slippery surfaces.

Additional important tips regarding tyre position

The **spare tyre's** date of manufacture and condition (e.g. signs of cracking, remaining tread depth) should be checked regularly. The spare tyre may have to be replaced.

For 4-wheel drive and All Wheel drive vehicles, any special tyre fitment requirements in the vehicle owner's manual should be heeded – especially if the vehicle is equipped with electronic systems such as antilock brakes, traction control or stability control. Damage to the vehicle or its transmission can result if these requirements are not followed.

Winter tyres should be fitted to all wheel positions. They should not be mixed with all-season or summer tyres. If winter tyres are, nonetheless, mounted on just one axle, this should be the rear axle. This increases rear-axle traction and helps to avoid oversteer and loss of vehicle stability on slippery roads.

Tyre Storage Recommendations

These recommendations are intended for consumers, but they are also important for tyre dealers. For commercial applications of new and waste tyres (tyre dealers and fleets), there may be more stringent and legal restrictions. Please check local regulations.

Tyres are compounded to resist normal deterioration caused e.g. by sunlight, humidity and ozone. Nevertheless, stored tyres should be protected against these and other potentially damaging conditions.

The longer the storage period, the more exposure there is to potential damage.

After dismounting from a vehicle the tyres should be thoroughly cleaned and inspected for damage. Remove all stones and debris from the grooves. Chalk marking the tyres with their wheel positions (FL for Front Left, RR for Rear Right, etc.) will help to find the correct positions according to the rotational plan.

General:

- DO STORE TYRES where it is clean, dark, dry and moderately ventilated.
- **Moist conditions** should be avoided. Tyres destined for retreading/repairing should be thoroughly cleaned and dried out before such operations are performed.
- DO STORE TYRES at **temperatures** not exceeding 35°C (95°F), preferable below 25°C (77°F). Direct contact with hot pipes and radiators must be avoided.
- Also deeply cold temperatures, those well below the freezing point, might lead to brittleness and tyres should be carefully warmed up before use.
- DO STORE TYRES, **if outdoors**, protected by an opaque waterproof covering, but avoid creating a heat box or steam bath. Ensure proper ventilation.
- DO STORE TYRES, if outdoors, where tyres are raised off the storage surface.
- **AVOID STORING TYRES** on piers, ship decks, or other unprotected areas

- **AVOID STORING TYRES**, where they can be damaged by passing objects – lawn mower, bicycle, or garden tools.
- **AVOID STORING TYRES** where the area is wet, oily, and/or greasy such as with gasoline or petroleum-based products. Also, do not store on or against sensitive surfaces where staining can take place.
- **AVOID STORING TYRES** in the proximity of chemical agents like solvents, fuels, oils, hydrocarbons, paint, acids, disinfectants, etc.
- **AVOID STORING TYRES** where subject to extreme temperatures, direct sunlight or artificial light with a high ultra-violet content. Room lighting with ordinary incandescent lamps is preferable to fluorescent tubes. **Never** store them near battery chargers, ovens, or open fires.
- **AVOID STORING TYRES** on black asphalt or other heat absorbent surfaces and on highly reflective surfaces (i.e., sand or snow covered ground)
- **AVOID STORING TYRES** in the same area as an electric motor or other ozone generating source. If there is a question, check ozone levels to be sure they do not exceed 0.08 ppm.
- **Do not** use tyres as a workbench or tool stand. Soldering irons, power drill and tools can damage a tyre. **Never** put a burning cigarette on a pile of tyres.
- **Do not** store other items on top of a tyre, especially where staining of the surface would be a concern.

Loose tyres or tyres mounted on rims, but not installed on a vehicle:

- DO STORE TYRES so that tyres retain their shape.
- Mounted tyres should preferably be inflated to only 100 kPa (15 psi / 1 bar).
- **Be sure to adjust the tyres to the recommended inflation pressure before mounting on the vehicle.**

Tyres with rims

Inflated

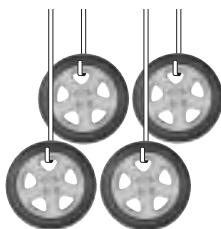

hang them

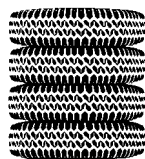

or pile them (restack every four weeks)

Do not stand them upright

Tyres without rims

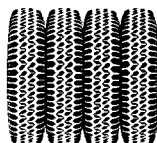

Do not pile them, or hang them

stand them upright and rotate them every four weeks (on racks clear of floor)

Tyres installed on a vehicle in long term storage:

- If possible, store the vehicle on blocks to remove all weight from the tyres and cover the tyres to protect them from environmental exposure.
- If the vehicle cannot be blocked up from the storage surface, completely unload the vehicle, so minimum weight will rest on the tyres. The storage surface should be firm, reasonably level, well drained, and clean.
- In cases where the tyres will be supporting the vehicle, it is permissible to inflate the tyres to the maximum pressure listed on the sidewall. Be sure to return the inflation pressure to recommended usage pressure before operating the vehicle.
- In cases where the tyres will be supporting the vehicle, it is recommended that the vehicle be moved every month to minimize ozone cracking in the bulge area and also to minimize a „flat spot“ from developing. If the tyres do develop „flat spots,“ they will usually disappear in a short period of service.

Before Returning Tyres (including full-size spares) to Service

- Inspect tyres to be sure they are clean and free from foreign objects.
- Remove any water that has collected in an unmounted tyre.
- When using a spare tyre, have it checked for proper inflation pressure and condition such as cracking in the tread or sidewalls, weather checking, and other signs of prolonged storage by a full-service tyre dealer, before placing it in service on the vehicle.

Full-Size Spare Tyres

Full size spares, of the same size and type as the road tyre, require special maintenance considerations.

The spare tyre position on the vehicle is frequently not suitable for long term storage for full size spare tyres that are not properly maintained / rotated as recommended. Tyres contain special ingredients such as waxes, etc. to protect the rubber. These special tyre ingredients

normally migrate throughout the tyre when in service and protect the tyre against deterioration caused e.g. by sunlight, humidity and ozone.

Therefore, full size spares that are left for prolonged periods of time in the spare tyre position should be inspected, properly inflated just like road tyres, and included in the regular tyre rotation.

Tyre repair



SAFETY WARNING:

Serious injury or death may result from a tyre disablement that is caused by failing to observe the following safety and

maintenance information.

During its service life, a tyre undergoes a variety of different usage conditions and can be damaged in many different ways. This damage can result from punctures, impacts, cuts, etc. Tyre damage can reduce a tyre's structural integrity by, for example:

- Air loss resulting in underinflated service conditions which lead to internal structural damage;
- Direct damage to tyre components such as rubber and plies;
- Exposure of internal materials to the outside environment and resulting degradation; and/or
- Exposure of internal materials to pressurized air (Intra-carcass pressurization).

For these reasons, tyres should be regularly inspected by the consumer. An inspection of the tyres should also be incorporated during routine vehicle maintenance procedures. If tyre damage is suspected or found, it should be carefully assessed by a trained tyre specialist immediately.

A consumer should never repair a damaged tyre. Only a trained tyre specialist who can base his assessment on a thorough and comprehensive inspection of the specific tyre can determine whether an individual tyre is suitable for repair or should be removed from service. This assessment should also take into account the complete service life history of the tyre including inflation, load, operating conditions, etc. If the tyre specialist decides to repair the tyre, then he should strictly follow all appropriate national tyre industry repair standards regarding the inspection process and repair procedures. Uniroyal is not responsible for the specialist's decisions or the repaired tyre. Uniroyal advises if a tyre is returned under complaint and reason for the product's disablement is in any way associated with a repair or the reason for repair the manufacturer's warranty is invalidated.

It is forbidden by law to regroove car tyres.

Tyre service life for passenger car and light truck

The tyre industry has long recognized the consumers' role in the regular care and maintenance of their tyres. The point at which a tyre is replaced is a decision for which the owner of the tyre is responsible. The tyre owner should consider factors to include service conditions, maintenance history, storage conditions, visual inspections, and dynamic performance. The consumer should consult a tyre service professional with any questions about tyre service life.

The following information and recommendations are made to aid in assessing the point of maximum service life.

Tyres are designed and built to provide many thousands of miles of excellent service. For maximum benefit, tyres must be maintained properly to avoid tyre damage and abuse that may result in tyre disablement. The service life

Operating instructions

of a tyre is a cumulative function of the storage, stowing, rotation and service conditions, which a tyre is subjected to throughout its life (load, speed, inflation pressure, road hazard injury, etc.). Since service conditions vary widely, accurately predicting the service life of any specific tyre in chronological time is not possible.

The consumer plays an important role in tyre maintenance.

Tyres should be removed from service for numerous reasons, including tread worn down to minimum depth, damage or abuse (punctures, cuts, impacts, cracks, bulges, underinflation, overloading, etc). For these reasons tyres, including spares, must be inspected routinely, i. e., at least once a month. Regular inspection becomes particularly important the longer a tyre is kept in service. If tyre damage is suspected or found, Uniroyal recommends that the consumer have the tyre inspected by a tyre service professional. Consumers should use this consultation to determine if the tyres can continue in service. It is recommended that spare tyres be inspected at the same time. This routine inspection should occur whether or not the vehicle is equipped with a tyre pressure monitoring system (TPMS).

Consumers are strongly encouraged to be aware of their tyres' visual condition. Also, they should be alert for any change in dynamic performance such as increased air loss, noise or vibration.

Such changes could be an indicator that one or more of the tyres should be immediately removed from service to prevent a tyre disablement. Also, the consumer should be the first to recognize a severe in-service impact to a tyre and to ensure that the tyre is inspected immediately thereafter.

Tyre storage, stowage and rotation are also important to the service life of the tyre. More information regarding proper storage, stowage and rotation is located in other Uniroyal publications, which are available upon request and through its websites.

Tyre service life recommendation

Uniroyal is unaware of any technical data that supports a specific tyre age for removal from service. However, as with other members of the tyre and automotive industries, Uniroyal recommends that all tyres (including spare tyres) that were manufactured more than ten (10) years previous¹⁾ be replaced with new tyres, even when tyres appear to be usable from their external appearance and if the tread depth may have not reached the minimum wear out depth. Vehicle manufacturers may recommend a different chronological age at which a tyre should be replaced based on their understanding of the specific vehicle application; Uniroyal recommends that any such instruction be followed. Consumers should note that most tyres would have to be removed for tread wear-out or other causes before any proscribed removal period. A stated removal period in no way reduces the consumer's responsibility to replace tyres as needed.

Minimum removal tread depth for passenger and light truck tyres

1.6 mm is the most widely accepted minimum tread depth standard at which tyres should be removed from service. This standard has been adopted as a regulation by many of the world's national transportation authorities. As an indication to the consumer, there are tread wear indicator bars in the main grooves of the tyre that become level with the tread surface at approximately 1.6 mm of remaining tread.

¹⁾ Production code of tyres [see page 5](#).

In addition to acknowledging the above, **Uniroyal recommends** that all passenger and light truck tyres in highway motor vehicle application be removed from service at the following tread depths:

- **summer/high performance tyres=3 mm**
- **winter tyres=4 mm**

These recommendations are based upon Uniroyal's testing as well as real world experience which shows that drivers can maintain

the performance potential (e.g. wet grip) of their tyres by replacing them before they reach the **regulatory minimum tread depth of 1.6 mm.**

This applies especially to winter tyres for which winter driving properties such as snow traction are significantly reduced at tread depths below 4 mm.

Publisher's imprint

The content of this publication is provided for information only and without responsibility. Continental AG makes no representations about the accuracy, reliability, completeness or timeliness of the information in this publication. Continental AG may, in its sole discretion, revise the information contained herein at any time without notice.

Continental AG's obligations and responsibilities regarding its products are governed solely by the agreements under which they are sold. Unless otherwise agreed in writing, the information contained herein does not become part of these agreements. This publication does not contain any guarantee or agreed quality of Continental AG's products or any warranty of merchantability, fitness for a particular purpose and non-infringement. Continental AG may make changes in the products or services described at any time without notice.

This publication is provided on an "as is" basis. To the extent permitted by law, Continental AG makes no warranty, express or implied, and assumes no liability in connection with the use of the information contained in this publication. Continental AG is not liable for any direct, indirect, incidental, consequential or punitive damages

arising out of the use of this publication. Information contained herein is not intended to announce product availability anywhere in the world.

The trademarks, service marks and logos (the Trademarks) displayed in this publication are the property of Continental and/or its affiliates. Nothing in this publication should be construed as granting any license or right to the Trademarks. Without the express written consent of Continental AG the use of the Trademarks is prohibited.

All text, images, graphics and other materials in this publication are subject to the copyright and other intellectual property rights of Continental AG and/or its affiliates. Continental AG owns the copyrights in the selection, coordination and arrangement of the materials in this publication. These materials may not be modified or copied for commercial use or distribution.

Copyright © 2009 Continental AG.
All rights reserved.

TD U 04/2009 **0410 196**



Operating instructions

Guidelines on tyre safety for drivers and vehicle operators (recommended for vehicle handbooks).

Tyres need to be properly handled if they are to keep you and other road users safe. So please note the following:

1. The **tyre pressure** must be as indicated in the operating instructions for your vehicle or as marked on the vehicle itself. The pressure applies to cold tyres; it must not be any lower. Tyres that have become warm, e.g. through driving, will increase in pressure. Never release air from warm tyres, or the pressure could fall below the minimum.

The pressure must be checked **every 14 days** when the tyres are cold. Don't forget to check the spare.

If the pressure is too low, heat may build up in the tyre and lead to internal damage.

At high speeds the tread may even come off and the tyre may have a blowout.

Tyre damage that cannot be seen is not put right simply by raising the pressure afterwards!

2. Drive over **kerbstones** slowly and, if possible, at right angles. Don't drive up or against any steep or sharp-edged kerbstones or other objects (e.g. stones); this can lead to non-visible tyre damage which can cause problems later – **the tyre may fail when running at high speeds.**

3. Check tyres regularly for **damage**, such as stones, nails etc. that have penetrated the tyre, as well as any cuts, tears or bulges (in the sidewall). Foreign objects can also damage the inside of the tyre. Let your tyre dealer or specialist check to see if the tyre can be repaired. If a repair is not possible or doubtful, replace the tyre. **Damaged tyres can burst.**

4. Never fit used tyres whose 'life story' you don't know. And remember that **tyres age** even when they are little used or not used at all. If your spare tyre remains unused for years, you should only use it in emergencies and drive carefully.

5. Check the **tread depth** of your tyres regularly. The lower the depth, the greater the **risk of aquaplaning**. Ensure that your tyres comply with the legally required tread depth.

A	Ageing	58, 60	N	New tyres	2, 47
	Aquaplaning	60	O	Offset depth	42
C	Choice of tyre	46		Operating conditions	2
D	DIN	2		Operating instructions	46-60
	Directional tyres	48, 54		Outer diameter	7, 16-28, 32, 34, 36
	DOT	2, 4		Overloading	53
E	ECE	2, 4-5	P	Production code	4, 5
	ETRTO	2, 51, 53	R	Regrooving	57
	EU	2, 5		Reinforced	5, 50
F	Fitting lubricant	47		Replacing 82-series by 80	46
	Fitting pressure	47		Rim codes	44
	Fuel consumption	50		Rim diameter	4, 5, 43, 45
H	H-rated tyre	6, 47, 50, 51, 52		Rim dimensions	43-45
	Higher grade tyres	46		Rim width	16-28, 32, 34, 36
I	Increasing tyre pressure	53		Rims/Wheels	42-45, 46
	Inflation pressure/ tyre pressure	2, 7, 48-51, 52, 60		Rolling circumference	7, 16-28, 32-37
L	Load capacity	16-28, 33, 35, 37, 38-40		Rolling resistance	50
	Load Index	4-6, 16-28, 32-37, 48-50			
M	M + S-tyres	4-5, 46			
	Max. inflation pressure	7, 50			
	Max. speed	4, 6, 46, 51-53			
	Measuring rim	16-28, 32, 34, 36, 46			
	Min. (tyre) pressure	50			
	Min. tread depth	59			
	Mixed tyre fitments	46			

Index

- S** Safety rims 44
Safety warning 2, 46, 47, 48, 57
Service conditions 2
Service life 57–58
Sidewall marking 4, 5
Size ranges 2, 8–15, 29–31
Spare tyres 6, 53, 56
Speed 2, 6, 46, 51–53
Speed Index 5–6
Static radius 7
Storage 54–57
Style of driving 53
Summer tyres 8–12, 15, 29, 30
- T** Technical data 16–28, 32–37
Trailers, car-drawn 38–40
Tread depth 5, 59, 60
Tubes 41, 47
Tubeless 4–5
TWI (Tread Wear Indicators) 5, 59
Twin fitment 53
Tyre ageing 58, 60
Tyre damages 53, 60
Tyre design 5
Tyre fitting 47
Tyre markings 5
Tyre pressure /
inflation pressure 2, 7, 48–51, 52, 60
Tyre repairs 57
Tyre service life 57–58
Tyre size 2, 46
Tyre strain 53
Tyre width 4–5, 7, 16–28, 32, 34, 36, 46
- U** Under-inflation 50, 53
Units of measurements 7
- V** V-rated tyres 6, 47, 50, 51, 52
Valve caps 48
Valve support 47
Van tyres 29–37
Vibrations 53
- W** W-rated tyres 6, 47, 50, 51, 52
Warning 2, 46, 47, 48, 57
Well-base rim 42, 44
Wheel camber 52
Wheel caps / trim rings 48
Wheels / rims 42–45, 46
Winter tyres 5, 13–14, 31, 46
- X** Extra-Load (XL) 5, 50
- Y** Y-rated tyres 6, 47, 50, 51, 52
- Z** ZR-rated tyres 6, 47, 50, 51, 52

D	Continental Aktiengesellschaft Head Office:	Büttnerstraße 25 30165 Hannover P.O.B. 169 30001 Hannover	Telephone: ++49-511-938-01 Telefax: ++49-511-938-81770 Telegramm: Continental Internet: www.conti-online.com
A	Semperit Reifen G.m.b.H. Marketing + Vertrieb Österreich	Wienersdorfer Straße 20–24 2514 Traiskirchen	Telephone: ++43-2252-501-0* Telefax: ++43-2252-501-3010
B	Continental Benelux S.A.	Excelsiorlaan 61 1930 Zaventem	Telephone: ++32-27102211 Telefax: ++32-27102290
CZ	Barum Continental sr.o.	76531 Otrokovice	Telephone: ++42-067-7514420 Telefax: ++42-067-7512075
CH	Continental Suisse S.A.	Lerzenstrasse 19 8953 Dietikon 1	Telephone: ++41-1/7455600 Telefax: ++41-1/7455630
DK	Continental Dæk Danmark A/S	Park Allé 370 2605 Brøndby	Telephone: ++45-43230400 Telefax: ++45-43230401
E	Continental Tires España, S.L.	Avda Castilla 1 Edificio 1 Planta 2 28830 San Fernando de Henares Madrid – España	Telephone: ++34-91-6603657 Telefax: ++34-91-6756822
F	Continental France snc	Lieu dit «Le Bac à l'Aumône» BP 10519 Clairoux 60205 Compiègne Cedex	Telephone: ++33-3-44407111 Telefax: ++33-3-44407489
GB	Continental Tyre Group Ltd.	191 High Street, West Drayton, Middlesex, UB7 7XW	Telephone: ++44-1895425900 Telefax: ++44-1895425908
H	Continental Hungaria Kft.	Táviró Köz 2–4 2040 Budaörs	Telephone: ++36-23-511183 Telefax: ++36-23-335463
I	Continental Italia S.p.A.	Via Pietro Rondoni 1, 20146 Milano	Telephone: ++39-02-424101 Telefax: ++39-02-42410200
NL	Continental Banden Groep B.V.	Nijverheidsweg 50 3771 ME Barneveld	Telephone: ++31-3-42497911 Telefax: ++31-3-42497380
N	Continental Dekk Norge A/S	Smalvollvejen 58 0611 Oslo	Telephone: ++47-23068000 Telefax: ++47-23068001
P	Continental Pneus S.A.	4760 Lousado Apartado 5029 Rua Adelino Leitao 330	Telephone: ++351-252-499234 Telefax: ++351-252-493623
PL	Continental Opony Polska Sp.zo.o.	Al. Krakowska 2a 02284 Warszawa	Telephone: ++48-22-5771300 Telefax: ++48-22-5771301
S	Continental Däck Sverige AB	Första Langgatan 30 40032 Gothenburg	Telephone: ++46-31-7758000 Telefax: ++46-31-246850
SF	Continental Rengas Oy	Itälähdenkatu 27A 00211 Helsinki	Telephone: ++358-9-329900 Telefax: ++358-9-32990400

0410 196

www.uniroyal-online.com

THE RAIN  TYRE



Footnotes

Size range

- available
- in preparation
- being phased out
- Rf. Reinforced
- XL Extra Load
- FR with rim protection

Technical data

- 1) Measuring rim in bold type.
- 2) Winter tyres can be max. 1% greater in outer diameter than standard on-road tread patterns.
- 3) At 37 mph/60 km/h.
- 4) Instead of B-rims, J- and JK-rims may also be used.
- 5) Load Index single/twin fitment and Speed Index.
- 6) Measuring rim in bold type. Dual spacing for twin tyre fitments: See Technical Data Book for truck tyres.
- 7) Standard = on road tread pattern,
Special = M + S or off-road tread pattern.
- 8) S = single / T = twin tyre fitment.
- *) 80 series passenger car tyres can be used instead of 82 series tyres and vice versa, without obtaining separate approval or without amending the entry in the vehicle registration document, providing the LI (Load Index) and SI (Speed Index) are suitable.
Example: 155 R13 79T replaced by 155/80 R13 79 T.

**For tyre pressures see "Operating instructions",
p. 48 ff.**
